

AN INTRODUCTION TO

electron microscopy

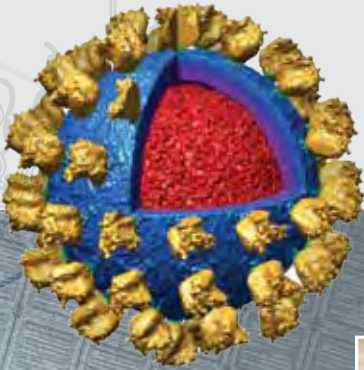

$\mu\text{m} = 10^{-6}$

nanotechnology



Ångström



TEMA

mikroskopeo

HISTORY

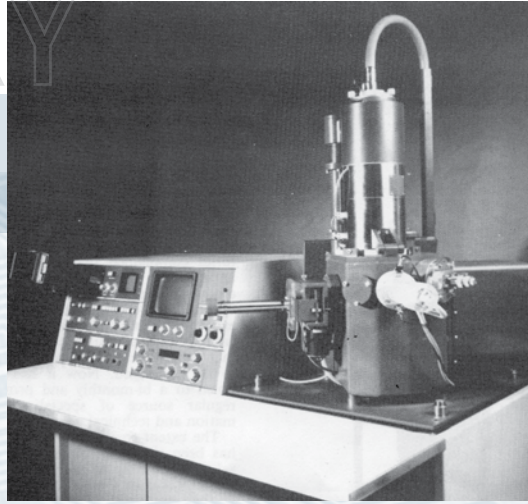
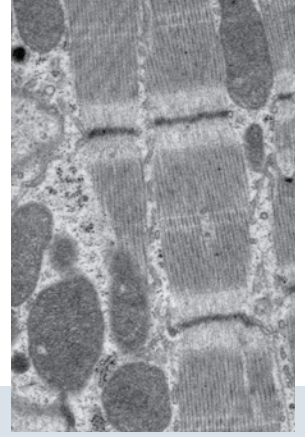

technology



THE NEW PHILIPS EM 200

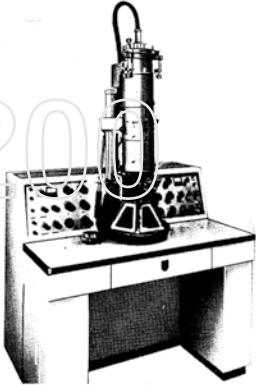

10 Å
RESOLVING
POWER
& BETTER

... with traditional PHILIPS ease of control

The new EM 200 electron microscope stems from the Philips expertise and research that produced the EM 100 and EM 15. Though it has a high performance, it is remarkably easy to use — a most important feature in this type of equipment.

Exact, rapid alignment of column - Direct, visual correction of alignment in less than a minute - Column having high degree of mechanical stability -

High-stability electronic circuits of unsurpassed performance - Magnification: 750 x 100,000 x on film 1,500 x 200,000 x on plates - Survey magnification down to 200 x - Double condenser lens for 1.5 μ beam spot - Built-in specimen chamber cooling device - Both roll film (40 exp.) and plates (12 pl.) - Built-in automatic shutter - Built-in vacuum de-venting chamber - Selected area electron diffraction - Accelerating voltage up to 100 kv.

Complete after-sales service can be provided under contract. Further information supplied on request Overseas enquiries, please, to the manufacturers, N. V. Philips,indhoven, The Netherlands

RESEARCH & CONTROL INSTRUMENTS LTD.
INSTRUMENT HOUSE, 37 KING'S CROSS ROAD, LONDON, W.C.1. TELEPHONE: FERNIX 1817



This booklet is a primer on electron and ion beam microscopy and is intended for students and others interested in learning more about the history, technology, and instruments behind this fascinating field of scientific inquiry. The goal of this booklet is to provide an overview of how electron and ion beam microscopes work, the results they can produce, and how researchers and scientists are using this data to address some of the greatest challenges of our time.

Most of the stunning nanoscale images displayed in this booklet have been colorized for visual effect and artistic impression.

Table of Contents

There's Plenty of Room at the Bottom...	2
Introduction	3
The Transmission Electron Microscope.....	9
The Scanning Electron Microscope	20
Scanning Transmission Electron Microscopy	26
Focused Ion Beam Systems and DualBeam™ Systems	28
Applications	32
Glossary	34



There's Plenty of Room at the Bottom



Richard Feynman delivering his lecture at Caltech on December 29th, 1959.

On December 29th, 1959, the noted physicist Richard Feynman issued an invitation to scientists to enter a new field of discovery with his lecture entitled “There’s Plenty of Room at the Bottom,” delivered at the annual meeting of the American Physical Society at the California Institute of Technology (Caltech). Many would credit this talk as the genesis of the modern field of nanotechnology. 2009 marked the 50th anniversary of his address and it is a fitting context in which to view the extraordinary progress that has been made over that period in the field of electron microscopy, one of the primary tools of nanoscience. Feynman called explicitly for an electron microscope 100 times more powerful than those of his day, which could only resolve features as small as about one nanometer. While we have not achieved the 100x goal – the best resolution achieved to date is 0.05 nm, a 20x improvement – we have indeed met his challenge to create a microscope powerful enough to see individual atoms.

About the publisher

FEI Company is a world leader in transmission and scanning electron and ion microscopy. Our commitment to microscopy dates back to the mid-1930s, when we collaborated in research programs with universities in the U.K. and The Netherlands. In 1949, the company introduced its first commercial product, the EM100 transmission electron microscope. Ever since, innovations in the technology and the integration of electron and ion optics, fine mechanics, microelectronics, computer sciences and vacuum engineering have kept FEI at the forefront of electron and ion microscopy. It is in this spirit of innovation and education that FEI has published our fourth edition of this booklet.



innovation

Introduction

The word microscope is derived from the Greek mikros (small) and skopeo (look at). From the dawn of science there has been an interest in being able to look at smaller and smaller details of the world around us. Biologists have wanted to examine the structure of cells, bacteria, viruses, and colloidal particles. Materials scientists have wanted to see inhomogeneities and imperfections in metals, crystals, and ceramics. In geology, the detailed study of rocks, minerals, and fossils on a microscopic scale provides insight into the origins of our planet and its valuable mineral resources.

Nobody knows for certain who invented the microscope. The light microscope probably developed from the Galilean telescope during the 17th century. One of the earliest instruments for seeing very small objects was made by the Dutchman Antony van Leeuwenhoek (1632-1723) and consisted of a powerful convex lens and an adjustable holder for the object being studied. With this remarkably simple microscope, Van Leeuwenhoek may well have been able to magnify objects up to 400x; and with it he discovered protozoa, spermatozoa, and bacteria, and was able to classify red blood cells by shape.

The limiting factor in Van Leeuwenhoek's microscope was the single convex lens. The problem can be solved by the addition of another lens to magnify the image produced by the first lens. This compound microscope – consisting of an objective lens and an eyepiece together with a means of focusing, a mirror or a source of light and a specimen table for holding and positioning the specimen – is the basis of light microscopes today.



Leeuwenhoek



Replica of one of the 550 light microscopes made by Antony van Leeuwenhoek.

Resolution of the Human Eye

Given sufficient light, the unaided human eye can distinguish two points 0.2 mm apart. If the points are closer together, they will appear as a single point. This distance is called the resolving power or resolution of the eye. A lens or an assembly of lenses (a microscope) can be used to magnify this distance and enable the eye to see points even closer together than 0.2 mm. For example, try looking at a newspaper picture, or one in a magazine, through a magnifying glass. You will see that the image is actually made up of dots too small and too close together to be separately resolved by your eye alone. The same phenomenon will be observed on an LCD computer display or flat screen TV when magnified to reveal the individual "pixels" that make up the image.

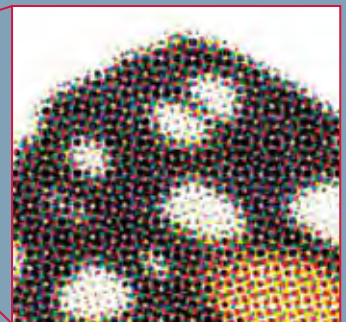

Types of microscopes

Most microscopes can be classified as one of three basic types: optical, charged particle (electron and ion), or scanning probe. Optical microscopes are the ones most familiar to everyone from the high school science lab or the doctor's office. They use visible light and transparent lenses to see objects as small as about one micrometer (one millionth of a meter), such as a red blood cell (7 μm) or a human hair (100 μm). Electron and ion microscopes, the topic of this booklet, use a beam of charged particles instead of light, and use electromagnetic or electrostatic lenses to focus the particles. They can see features as small as a tenth of a nanometer (one ten billionth of a meter), such as individual atoms. Scanning probe microscopes use a physical probe (a very small, very sharp needle) which scan over the sample in contact or near-contact with the surface. They map various forces and interactions that occur between the probe and the sample to create an image. These instruments too are capable of atomic scale resolution.

A modern light microscope (often abbreviated to LM) has a magnification of about 1000x and enables the eye to resolve objects separated by 200 nm. As scientists and inventors toiled to achieve better resolution, they soon realized that the resolving power of the microscope was not only limited by the number and quality of the lenses, but also by the wavelength of the light used for illumination. With visible light it was impossible to resolve points in the object that were closer together than a few hundred nanometers. Using light with a shorter wavelength (blue or ultraviolet) gave a small improvement. Immersing the specimen and the front of the objective lens in a medium with a high refractive index (such as oil) gave another small improvement, but these measures together only brought the resolving power of the microscope to just under 100 nm.

In the 1920s, it was discovered that accelerated electrons behave in vacuum much like light. They travel in straight lines and have wave-like properties, with a wavelength that is about 100,000 times shorter than that of visible light. Furthermore, it was found that electric and magnetic fields could be used to shape the paths followed by electrons similar to the way glass lenses are used to bend and focus visible light. Ernst Ruska at the University of Berlin combined these characteristics and built the first transmission electron microscope (TEM) in 1931. For this and subsequent work on the subject, he was awarded the Nobel Prize for Physics in 1986. The first electron microscope used two magnetic lenses, and three years later he added a third lens and demonstrated a resolution of 100 nm, twice as good as that of the light microscope. Today, electron microscopes have reached resolutions of better than 0.05 nm, more than 4000 times better than a typical light microscope and 4,000,000 times better than the unaided eye.



Ernst
Ruska

Resolution and Wavelength

When a wave passes through an opening in a barrier, such as an aperture in a lens, it is diffracted by the edges of the aperture. Even a perfectly shaped lens will be limited in its resolving power by diffraction. This is why a high quality optical lens may be referred to as a diffraction-limited lens – it is as good as it can be and any further effort to improve the quality of the lens surface will not improve its resolution. The amount of diffraction is a function of the size of the aperture and the wavelength of the light, with larger apertures and/or shorter wavelengths permitting better resolution. The wavelength of an electron in a TEM may be only a few picometers (1 pm = 10^{-12} m), more than 100,000 times shorter than the wavelength of visible light (400-700 nm). Unfortunately, the magnetic lenses used in electron microscopes do not approach diffraction-limited performance and so electron microscopes have been unable to take full advantage of the shorter wavelength of the electron. Ultimately, the resolving power of an electron microscope is determined by a combination of beam voltage, aperture size, and lens aberrations.

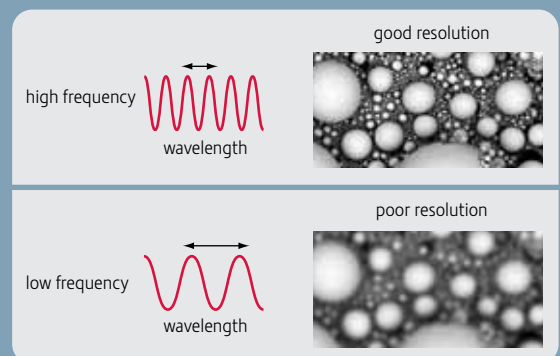

Scanning Microscopy

Imagine yourself alone in an unknown darkened room with only a narrowly focused flashlight. You might start exploring the room by scanning the flashlight systematically from side to side gradually moving down (a raster pattern) so that you could build up a picture of the objects in the room in your memory. A scanning electron microscope uses an electron beam instead of a flashlight, an electron detector instead of your eyes, and a computer memory instead of your brain to build an image of the specimen's surface.

The Electron

An atom is made up of three kinds of particles – protons, neutrons, and electrons. The positively charged protons and neutral neutrons are held tightly together in a central nucleus. Negatively charged electrons surround the nucleus. Normally, the number of protons equals the number of electrons so that the atom as a whole is neutral. When an atom deviates from this normal configuration by losing or gaining electrons, it acquires a net positive or negative charge and is referred to as an ion. The electrons, which are about 1800 times lighter than the nuclear particles, occupy distinct orbits, each of which can accommodate a fixed maximum number of electrons. When electrons are liberated from the atom, however, they behave in a manner analogous to light. It is this behavior which is used in the electron microscope, although we should not lose sight of the electron's role in the atom, to which we will return later.

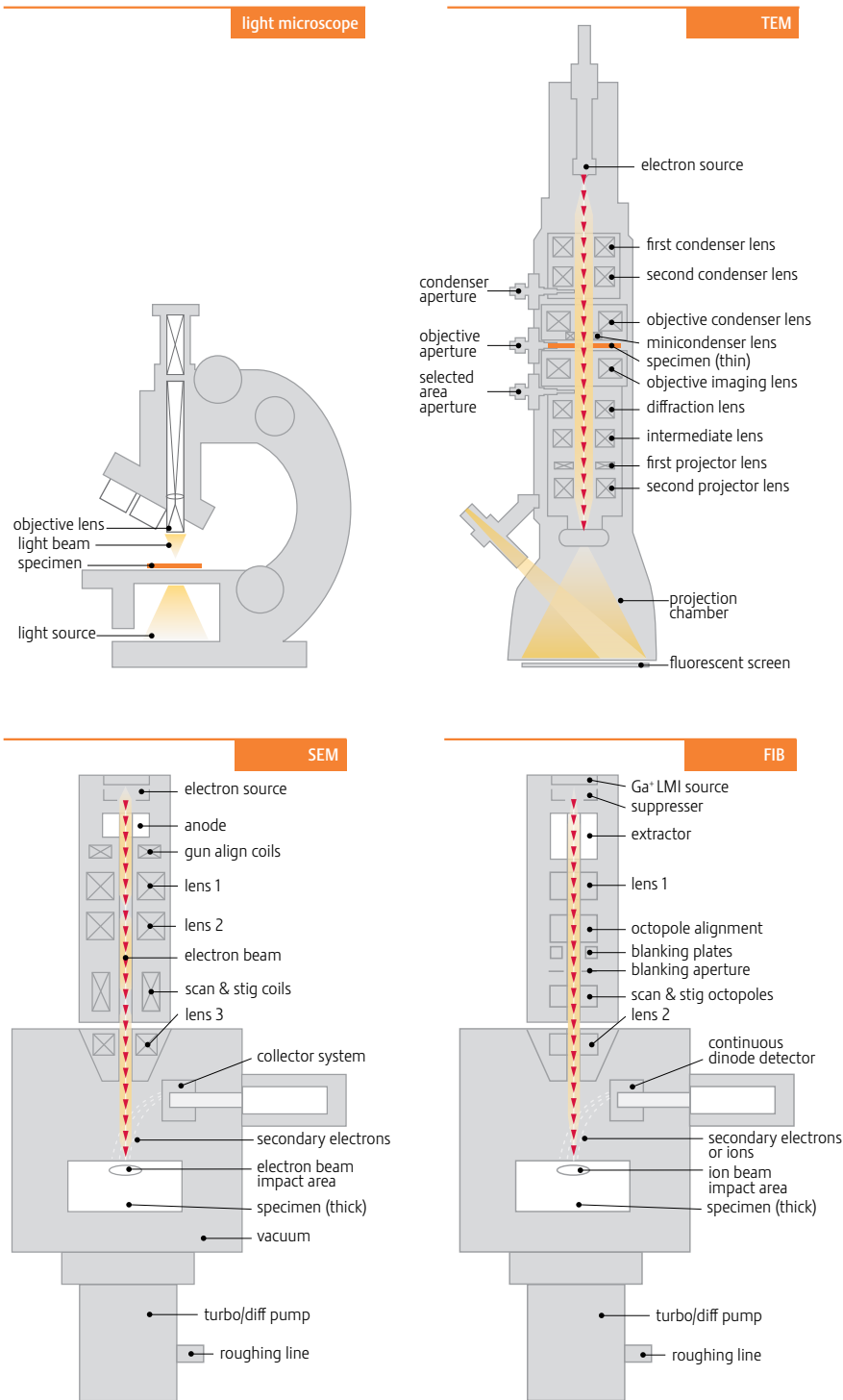
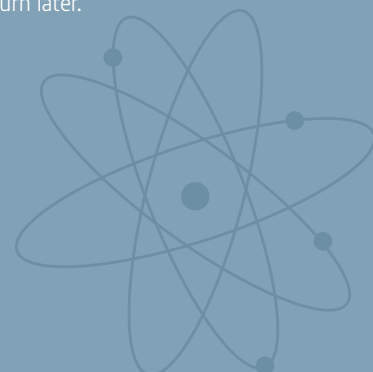

Fig. 1 Comparison of the light microscope with TEM, SEM, and FIB microscopes.

Transmission electron microscopy

The transmission electron microscope can be compared with a slide projector. In a slide projector light from a light source is made into a parallel beam by the condenser lens; this passes through the slide (object) and is then focused as an enlarged image onto the screen by the objective lens. In the electron microscope, the light source is replaced by an electron source, the glass lenses are replaced by magnetic lenses, and the projection screen is replaced by a fluorescent screen, which emits light when struck by electrons, or, more frequently in modern instruments, an electronic imaging device such as a CCD (charge-coupled device) camera. The whole trajectory from source to screen is under vacuum and the specimen (object) has to be very thin to allow the electrons to travel through it. Not all specimens can be made thin enough for the TEM. Alternatively, if we want to look at the surface of the specimen, rather than a projection through it, we use a scanning electron or ion microscope.

Scanning electron microscopy

It is not completely clear who first proposed the principle of scanning the surface of a specimen with a finely focused electron beam to produce an image. The first published description appeared in 1935 in a paper by the German physicist Max Knoll. Although another German physicist, Manfred von Ardenne, performed some experiments with what could be called a scanning electron microscope (SEM) in 1937. It was not until 1942 that three Americans, Zworykin, Hillier, and Snijder, first described a true SEM with a resolving power of 50 nm. Modern SEMs can have resolving power better than 1 nm. Fig. 1 compares light microscopy (using transmitted or reflected light) with TEM, SEM, and FIB.

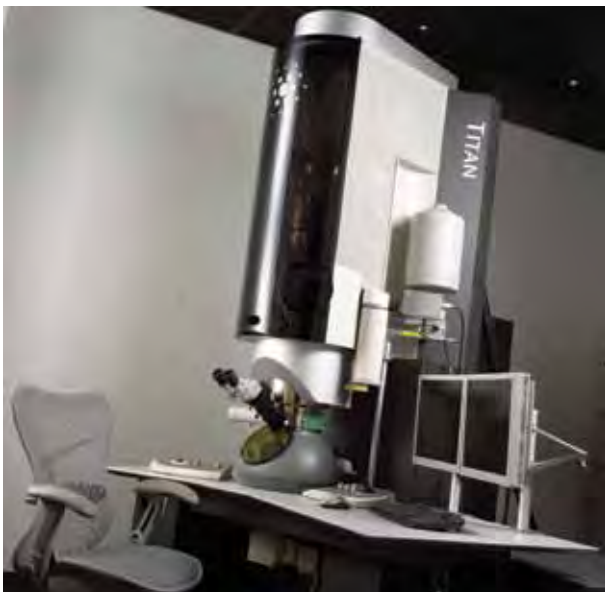

A modern transmission electron microscope – the Titan™ 80-300.

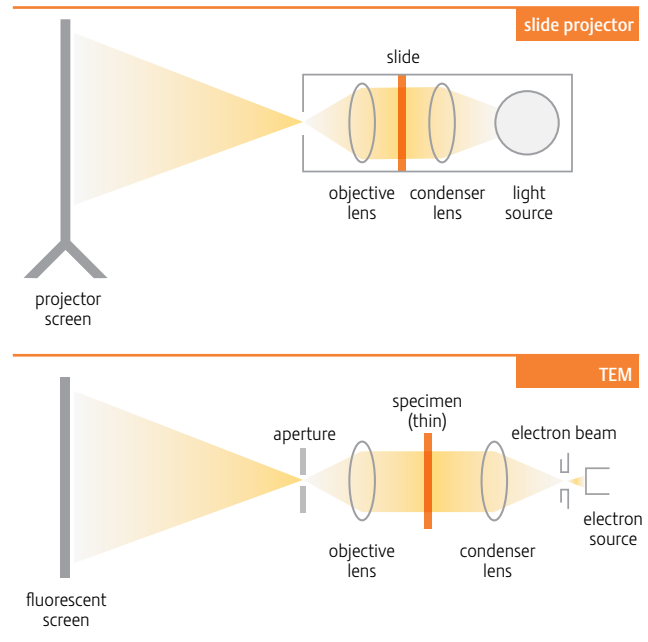
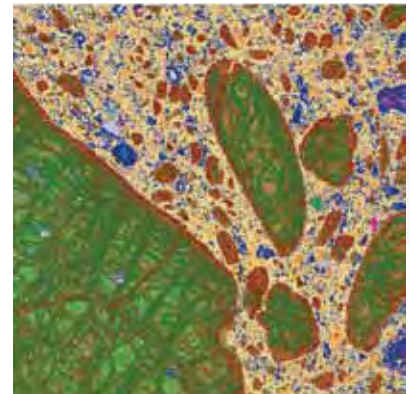

Fig. 2 The transmission electron microscope compared with a slide projector.



Diamond-bearing ore from South Africa.



Gold nanobridge at the atomic level.

TEM

Scanning transmission electron microscopy

A microscope combining the principles used by both TEM and SEM, usually referred to as scanning transmission electron microscopy (STEM), was first described in 1938 by Manfred von Ardenne. It is not known what the resolving power of his instrument was. The first commercial instrument in which the scanning and transmission techniques were combined was a Philips EM200 equipped with a STEM unit developed by Ong Sing Poen of Philips Electronic Instruments in the U.S. in 1969. It had a resolving power of 25 nm. Modern TEM systems equipped with STEM facility can achieve resolutions down to 0.05 nm in STEM mode.

Focused ion beam and DualBeam microscopy

A focused ion beam (FIB) microscope is similar to a SEM except the electron beam is replaced by a beam of ions, usually positively charged gallium (Ga^+). A FIB can provide high resolution imaging (with resolution as good as a few nanometers), and because the ions are much more massive than electrons, the FIB can also be used to sputter (remove) material from the sample with very precise control. A FIB may be combined with a SEM in a single instrument (FIB/SEM). In FEI's DualBeam™ FIB/SEM instruments, the electron and ion column are positioned to allow the SEM to provide immediate high resolution images of the surface milled by the FIB.

Penetration

Electrons are easily stopped or deflected by matter (an electron is nearly 2000x smaller and lighter than the smallest atom). That is why the microscope has to be evacuated and why specimens – for the transmission microscope – have to be very thin. Typically, for electron microscopy studies, a TEM specimen must be no thicker than a few hundred nanometers. Different thicknesses provide different types of information. For present day electron microscopy studies, thinner is almost always better. Specimens as thin as a few tenths of a nanometers can be created from some materials using modern preparation techniques. While thickness is a primary consideration, it is equally important that the preparation preserve the specimen's bulk properties and not alter its atomic structure – not a trivial task.

The Nanometer

As distances become shorter, the number of zeros after the decimal point becomes larger, so microscopists use the nanometer (abbreviated to nm) as a convenient unit of length. One nanometer is a billionth (10^{-9}) of a meter. An intermediate unit is the micrometer (abbreviated to μm), which is a millionth (10^{-6}) of a meter or 1000 nm. Some literature refers to the Ångström unit (Å), which is 0.1 nm and use micron for micrometer. A picometer is a trillionth (10^{-12}) of a meter.

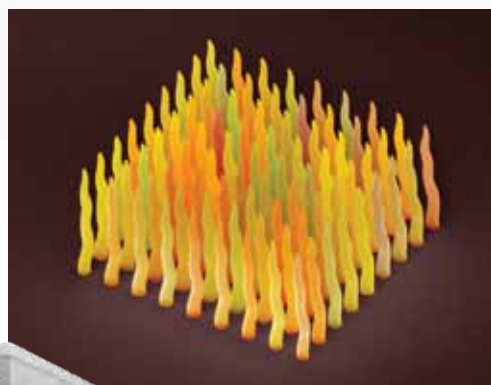
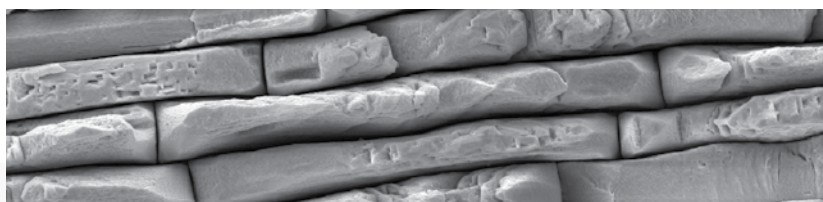

Platinum Nanorods on Silicon.

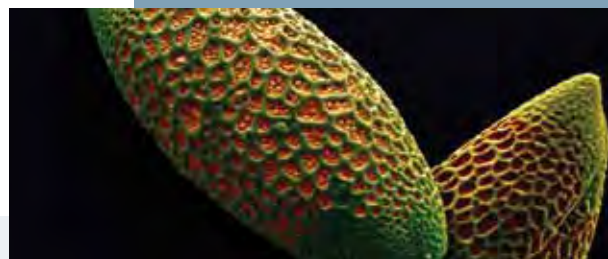

Resolution and Magnification

The resolving power of a microscope determines its maximum useful magnification. For instance, if a microscope has a resolving power of 200 nm (typical of a light microscope), it is only useful to magnify the image by a factor of 1000 to make all the available information visible. At that magnification, the smallest details that the optical system can transfer from the object to the image (200 nm) are large enough to be seen by the unaided eye (0.2 mm). Further magnification makes the image larger (and more blurred), but does not reveal additional detail.

Magnification in excess of the maximum useful magnification is sometimes referred to as “empty resolution.” Notwithstanding the limiting principle of maximum useful resolution, it is often convenient, for a variety of practical or aesthetic reasons, to use higher magnifications; and commercial instruments typically offer magnification capability well beyond the maximum useful magnification implied by their resolving power. This text will emphasize resolving power as the primary measure of an instrument’s imaging capability, and refer to magnification only to provide a relative sense of scale among various electron microscopy techniques. When a more precise usage of magnification is required, it will be cited explicitly.

Magnification is often quoted for an image because it gives a quick idea of how much the features of the specimen have been enlarged. However, a magnification that was accurate when that image is projected on a large screen as part of a presentation or reproduced at a smaller size in a printed publication. For this reason, most microscopes now routinely include reference scale markers of known length that scale accurately as the image is enlarged or reduced for various uses.

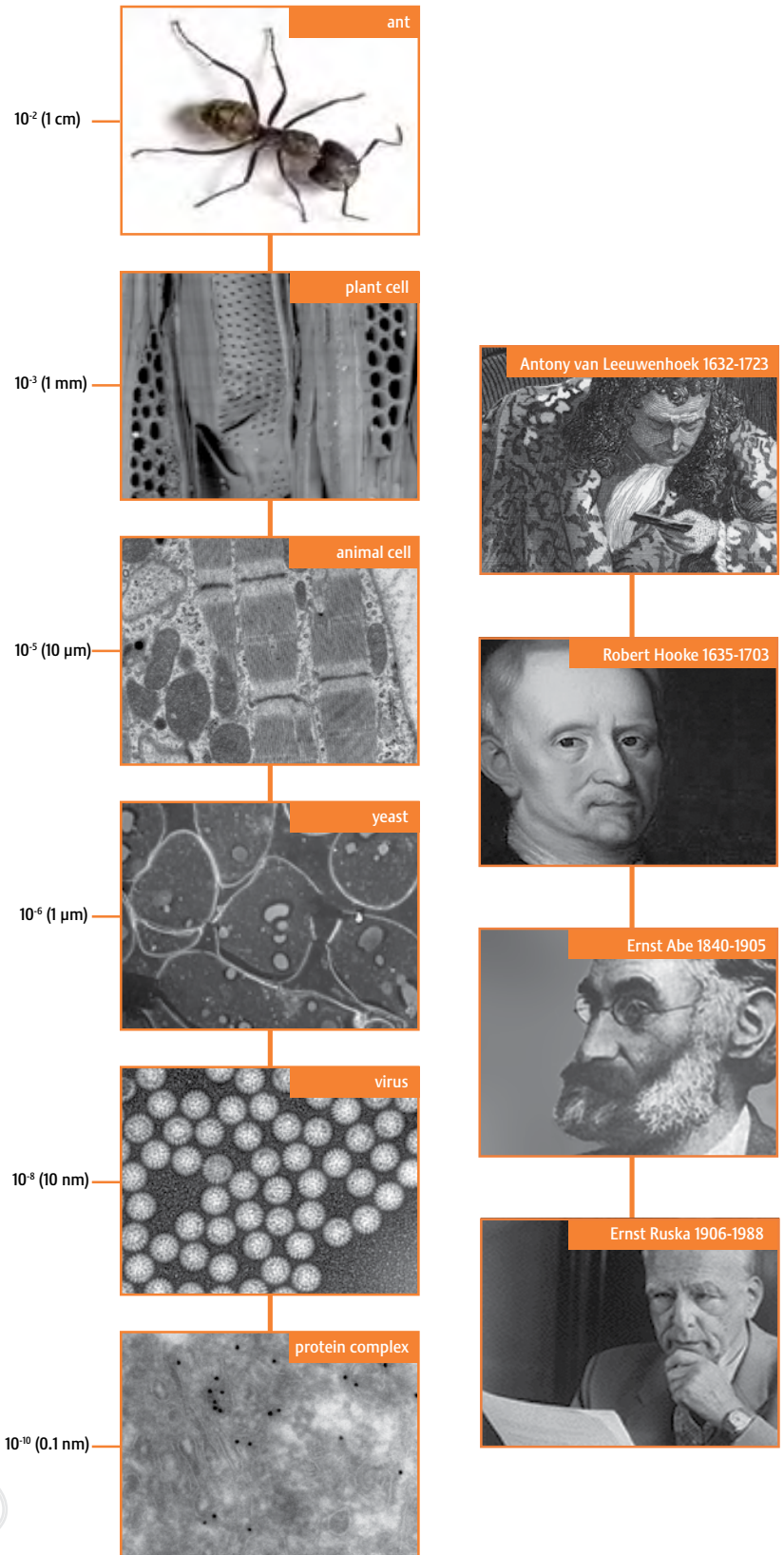
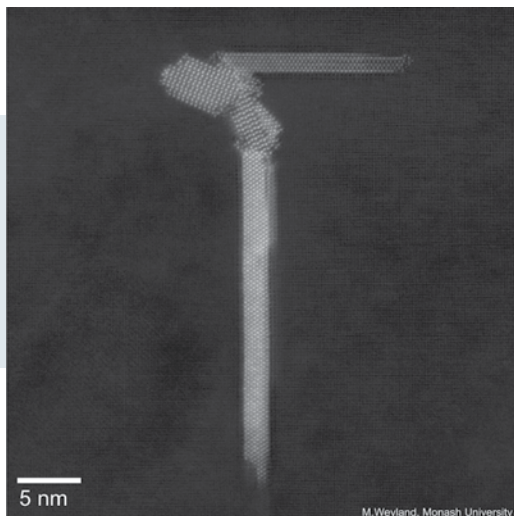

Fig. 3 The Resolution Scale.

The Transmission Electron Microscope

There are four main components to a transmission electron microscope: an electron optical column, a vacuum system, the necessary electronics (lens supplies for focusing and deflecting the beam and the high voltage generator for the electron source), and control software. A modern TEM typically comprises an operating console surmounted by a vertical column and containing the vacuum system, and control panels conveniently placed for the operator. The microscope may be fully enclosed to reduce interference from environmental sources. It may even be operated remotely, removing the operator from the instrument environment to the benefit of both the operator and the instrument.

The electron column includes elements analogous to those of a light microscope. The light source of the light microscope is replaced by an electron gun, which is built into the column. The glass lenses are replaced by electromagnetic lenses. Unlike glass lenses, the power (focal length) of magnetic lenses can be changed by changing the current through the lens coil. (In the light microscope, variation in magnification is obtained by changing the lens or by mechanically moving the lens). The eyepiece or ocular is replaced by a fluorescent screen and/or a digital camera. The electron beam emerges from the electron gun (usually at the top of the column), and is condensed into a nearly parallel beam at the specimen by the condenser lenses. The specimen must be thin enough to transmit the electrons, typically $0.5\ \mu\text{m}$ or less. Higher energy electrons (i.e., higher accelerating voltages) can penetrate thicker samples. After passing through the specimen, transmitted electrons are collected and focused by the objective lens and a magnified real image of the specimen is projected by the projection lens(es) onto the viewing device at the bottom of the column. The entire electron path from gun to camera must be under vacuum (otherwise the electrons would collide with air molecules and be scattered or absorbed).



Atomic resolution STEM image of nanoscale precipitates in an Al-Cu-Li-Mg-Ag aerospace alloy.

A modern transmission electron microscope – the Titan™ 80-300.



The electron gun

Three main types of electron sources are used in electron microscopes: tungsten, lanthanum hexaboride (LaB_6 - often called “lab six”), and field emission gun (FEG). Each represents a different combination of costs and benefits. The choice of source type is an important part of the instrument selection process. Perhaps the single most important characteristic of the source is brightness, which characterizes the electron current density of the beam and the angle into which the current is emitted (current density per steradian solid angle); and ultimately determines the resolution, contrast and signal-to-noise capabilities of the imaging system. FEG sources offer brightness up to 1000 times greater than tungsten emitters, but they are also much more expensive. In some high current applications, LaB_6 or tungsten may actually work better than FEG.

A tungsten gun comprises a filament, a Wehnelt cylinder, and an anode. These three together form a triode gun, which is a very stable source of electrons. The tungsten filament is hairpin-shaped and heated to about 2700°C . By applying a high positive potential difference between the filament and the anode, thermally excited electrons are extracted from the electron cloud near the filament and accelerated towards the anode. The anode has a hole in it so that an electron beam, in which the electrons may travel faster than two

thousand kilometers per second, emerges and is directed down the column. The Wehnelt cylinder, which is held at a variable potential slightly negative to the filament, directs the electrons through a narrow cross-over to improve the current density and brightness of the beam (Fig. 4). Tungsten sources are least expensive, but offer lower brightness and have limited lifetimes. The brightness of a tungsten source can be increased, but only at the cost of shorter lifetime. Because the emission area is large, a tungsten source can provide very high total beam current.

Like tungsten, LaB_6 guns depend on thermionic emission of electrons from a heated source, a lanthanum hexaboride crystal. LaB_6 sources can provide up to 10x more brightness than tungsten and have significantly longer lifetimes, but require higher vacuum levels, which increases the microscope’s cost. The emitting area of LaB_6 is smaller than tungsten, increasing brightness but reducing total beam current capability.

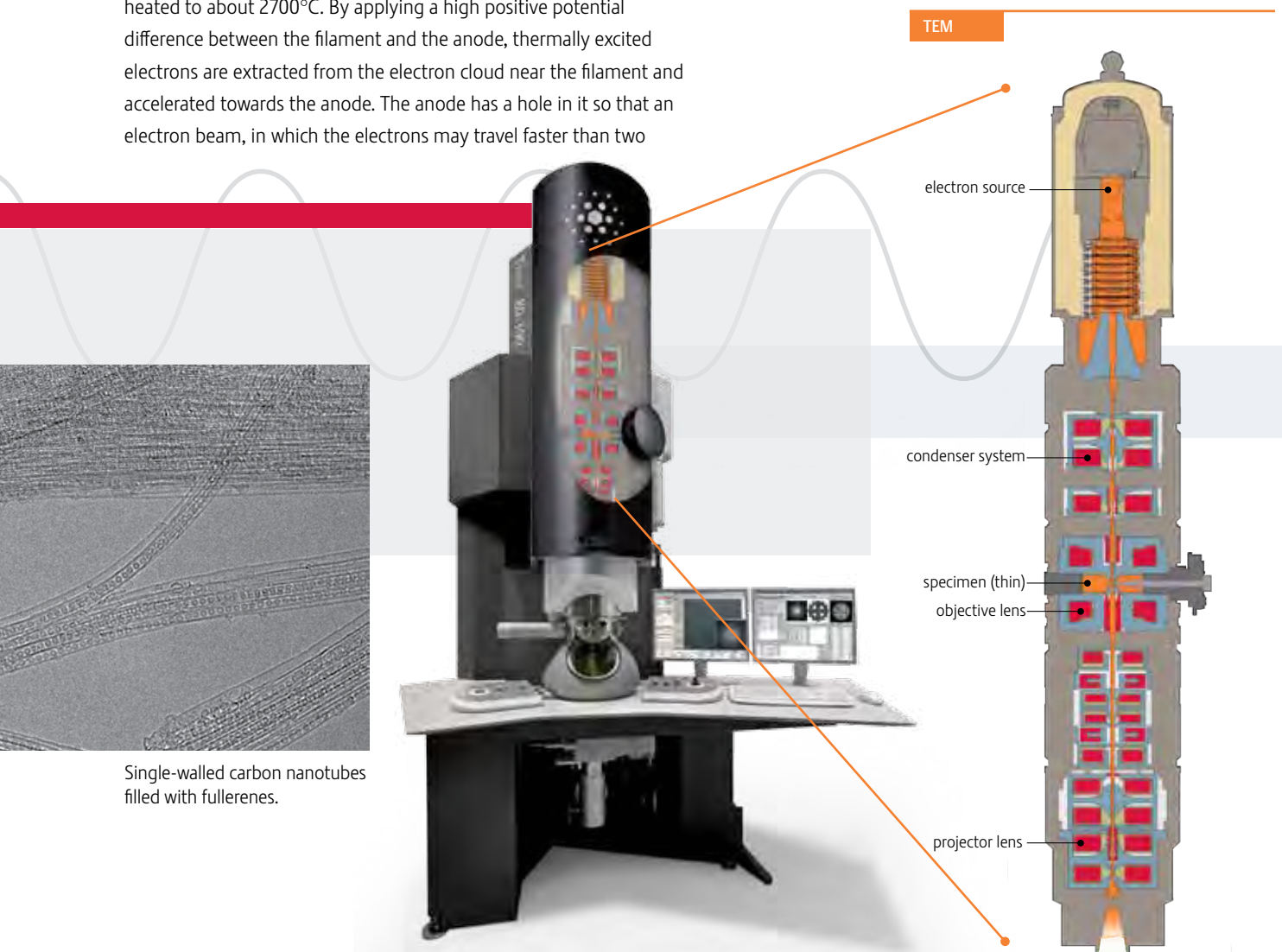

Single-walled carbon nanotubes filled with fullerenes.

Cross section of the column of a modern transmission electron microscope.

Field emission guns, in which the electrons are extracted from a very sharply pointed tungsten tip by an extremely high electric field, are the most expensive type of source, but generally provide the highest imaging and analytical performance. High resolution TEM, based on phase contrast, requires the high spatial coherence of a field emission source. The higher brightness and greater current density provided by these sources produce smaller beams with higher currents for better spatial resolution and faster, more precise X-ray analysis.

Field emission sources come in two types, cold field emission and Schottky (thermally assisted) field emission. Cold field emission offers very high brightness but varying beam currents. It also requires frequent flashing to clean contaminants from the tip. Schottky field emission offers high brightness and high, stable current with no flashing. The latest generation of Schottky field emitters (FEI XFEG) retains its current stability while attaining brightness levels close to cold field emission.

As a rule of thumb, if the application demands imaging at magnifications up to 40-50 kX in TEM mode, a tungsten source is typically not only adequate, but the best source for the application. When the TEM imaging magnification is between 50-100 kX, then the brightest image on the screen will be generated using a LaB₆ source. If magnifications higher than 100 kX are required, a field emission source gives the better signal. In the case of small probe experiments such as analytical or scanning techniques, then a field emission gun is always preferred.

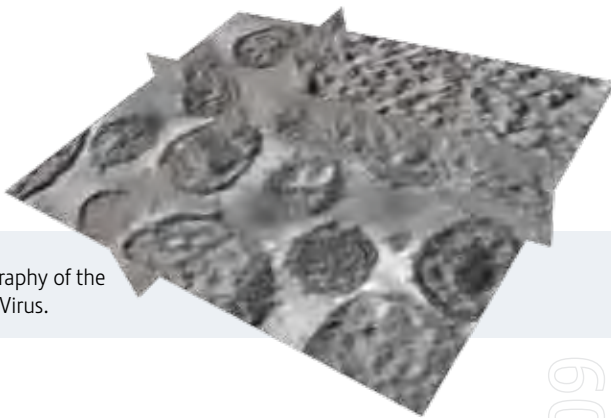

Electron tomography of the budding of HIV Virus.

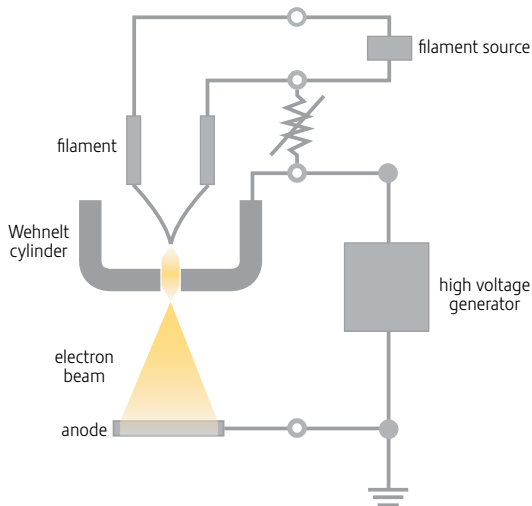

Fig. 4 Schematic cross section of the electron gun in an electron microscope.

60 million electrons

Electron Velocity

The higher the accelerating voltage, the faster the electrons. 80 kV electrons have a velocity of 150,000 km/second (1.5×10^8 m/s), which is half the speed of light. This rises to 230,000 km/second for 300 kV electrons (2.3×10^8 m/s – more than three-quarters the speed of light). The wave particle duality concept of quantum physics asserts that all matter exhibits both wave-like and particle-like properties. The wavelength λ of an electron is given by

$$\lambda = \frac{h}{p}$$

where h is Planck's constant and p is the relativistic momentum of the electron. Knowing the rest mass of an electron m_0 , and its charge e , we can calculate the velocity v imparted by an electric potential U as

$$v = \sqrt{\frac{2eU}{m_0}}$$

and wavelength at that velocity as

$$\lambda = \frac{h}{p} = \frac{h}{m_0 v} = \frac{h}{\sqrt{2m_0 eU}}$$

Finally, since the velocities attained are a significant fraction of the speed of light c , we add a relativistic correction to get

$$\lambda = \frac{h}{\sqrt{2m_0 eU}} \frac{1}{\sqrt{1 + \frac{eU}{2m_0 c^2}}}$$

The wavelength of the electrons in a 10 kV SEM is then 12.3×10^{-12} m (12.3 pm), while in a 200 kV TEM the wavelength is 2.5 pm.

Electron Density

A typical electron beam has a current of about 10 picoamperes ($1 \text{ pA} = 10^{-12}$ A). One ampere is 1 coulomb/sec. The electron has a charge of 1.6×10^{-19} coulomb. Therefore, approximately 60 million electrons per second impinge on the specimen. However, because of their high speed, the average distance between electrons (at 200,000 km/second) would be over three meters. Most electrons transit the specimen one at a time.

What happens in the specimen during the electron bombardment?

Contrary to what might be expected, most specimens are not adversely affected by the electron bombardment as long as beam conditions are controlled judiciously. When electrons impinge on the specimen, they can cause any of the following:

- Some of the electrons are absorbed as a function of the thickness and composition of the specimen; these cause what is called amplitude (or mass thickness) contrast in the image.
- Other electrons are scattered over small angles, depending on the composition and structure of the specimen; these cause what is called phase contrast in the image.
- In crystalline specimens, the electrons are scattered in very distinct directions that are a function of the crystal structure; these cause what is called diffraction contrast in the image.
- Some of the impinging electrons are deflected through large angles or reflected (backscattered) by sample nuclei.
- The impinging electrons can knock electrons from sample atoms which escape as low energy secondary electrons.
- The impinging electrons may cause specimen atoms to emit X-rays whose energy and wavelength are related to the specimen's elemental composition; these are called characteristic X-rays.
- The impinging electrons cause the specimen to emit photons (or light); this is called cathodoluminescence.
- Finally, transmitted beam electrons can be counted and sorted by an energy loss spectrometer according to the amount of energy they have lost in interactions with the specimen. The energy loss carries information about the elemental, chemical, and electronic states of the sample atoms.

In a standard TEM, mass thickness is the primary contrast mechanism for non-crystalline (biological) specimens, while phase contrast and diffraction contrast are the most important factors in image formation for crystalline specimens (most non-biological materials).

The electromagnetic lenses

Fig. 5 shows a cross-section of an electromagnetic lens. When an electric current is passed through the coils (C), an electromagnetic field is created between the pole pieces (P), which forms a gap in the magnetic circuit. By varying the current through the coils, the strength of the field, and thereby the power of the lens, can be varied. This is the essential difference between the magnetic lens and the glass lens. Otherwise they behave similarly and have the same types of aberration (Fig. 6): spherical aberration (C_s – the power in the center of the lens differs from that at the edges), chromatic aberration (C_c – the power of the lens varies with the energy of the electrons in the beam), and astigmatism (a circle in the specimen becomes an ellipse in the image).

In a conventional TEM, spherical aberration, which is largely determined by the lens design and manufacture, is the primary limitation to improved image resolution. Chromatic aberration can be reduced by keeping the accelerating voltage as stable as possible and using very thin specimens. Astigmatism can be corrected by using variable electromagnetic compensation coils.

The condenser lens system focuses the electron beam onto the specimen under investigation as much as necessary to suit the purpose. The objective lens produces an image of the specimen which is then magnified by the remaining imaging lenses and projected onto the viewing device.

If the specimen is crystalline, a diffraction pattern will be formed at a point below the objective lens known as the back focal plane. By varying the strengths of the lenses immediately below the objective lens, it is possible to enlarge the diffraction pattern and project it onto the viewing device. The objective lens is followed by several projection lenses used to focus, magnify, and project the image or diffraction pattern onto the viewing device. To guarantee high stability and to achieve the highest possible lens strength/magnification, the lenses in a modern TEM are usually water-cooled.

On the way from the source to the viewing device, the electron beam passes through a series of apertures with different diameters. These apertures stop those electrons that are not required for image formation (e.g., scattered electrons). Using a special holder carrying a number of different size apertures, the diameter of the apertures in the condenser lens, the objective lens, and the diffraction lens can be changed as required.

Aberration-corrected TEM

The recent development of a dedicated commercial aberration-corrected TEM has enabled major advances in both TEM and STEM capability. Without correction, TEM resolution is limited primarily by spherical aberration, which causes information from a point in the object to be spread over an area in the image. This results not only in a general blurring of the image, but also in a phenomenon called delocalization, in which periodic structures appear to extend beyond

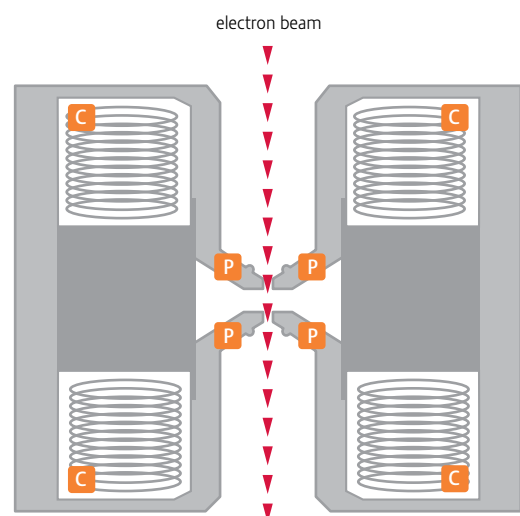

Fig. 5 Cross-section of an electromagnetic lens. C is an electrical coil and P is the soft iron pole piece. The electron trajectory is from top to bottom.

their actual physical boundaries. In a light microscope, spherical aberration can be minimized by combining lens elements that have opposing spherical aberrations. This approach cannot be used in electron microscopes since the round magnetic lenses they use exhibit only positive spherical aberration. Multi-pole correcting elements (with essentially negative aberration) were described by Otto Scherzer in 1947, but their successful commercial implementation required solutions to a number of practical problems; some relatively simple, as for example, increasing the diameter of the electron column to achieve the mechanical stability required to actually see the benefit of improved optical performance; and others very complex, such as designing sufficiently stable power supplies and developing methods and software controls sophisticated enough to reliably measure and then correct the aberrations by independently exciting the multi-pole elements.

The ability to correct spherical aberration leaves the reduction or correction of the effects of chromatic aberration as the next major challenge in improving TEM performance. Chromatic aberration correctors have been successfully incorporated into the Titan™ TEM platform, but their design and operation are substantially more complex than spherical aberration correctors. At the same time, significant progress has been made in reducing the energy spread of electrons passing through the lenses. The energy spread determines the magnitude of chromatic aberration's deleterious effects. Variations in electron energy may originate as the beam is formed in the electron gun, or they may be introduced in transmitted electrons by interactions with sample atoms. The first of these, beam energy spread, has been addressed by engineering extremely stable high voltage and lens current power supplies, by using specially optimized field emission electron sources, and by directing the beam through a monochromator, which passes only a very narrow band of energies. The energy spread among electrons transmitted through the specimen can be decreased by minimizing sample thickness using advanced sample preparation techniques.

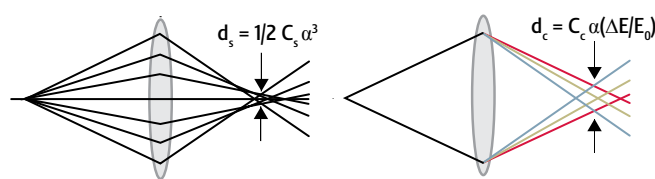
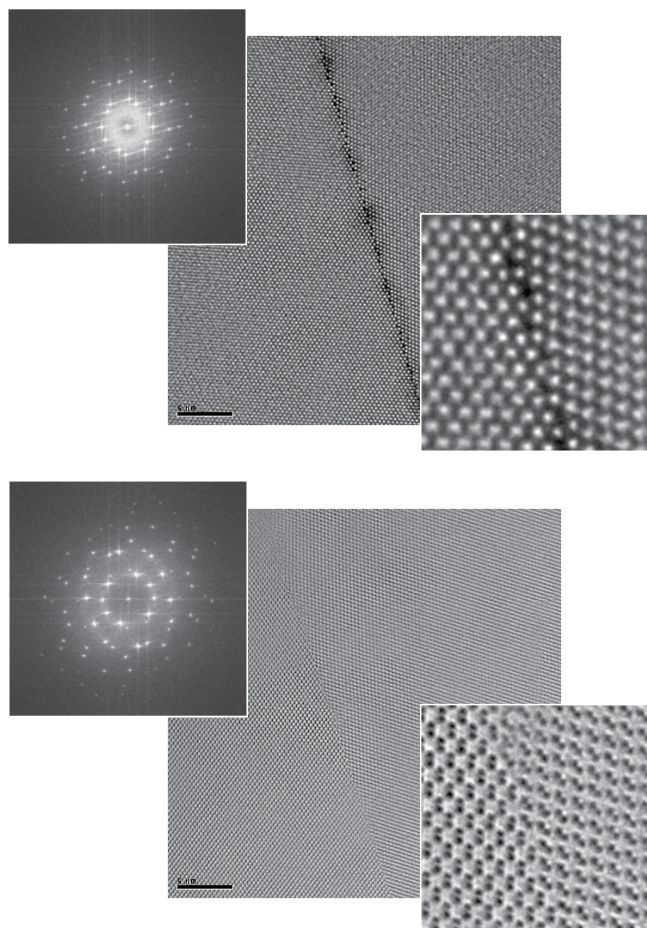

Fig. 6 Lens aberrations C_s (left) and C_c (right).



Comparison of HR-TEMs with (lower) and without (upper) C_s -correction on the same Si<110> grain boundary at 300 kV.

Image Resolution and Information Limit

Prior to the development of spherical aberration correctors, scientists knew that a TEM was capable of providing information from the sample with higher spatial resolution than could be observed directly in the image. The directly observable resolution, known as point resolution, was limited by spherical aberration of the lenses. However, by appropriately combining data from multiple images in a “through-focus series” (acquired over a range of defocus values), they could reconstruct a model image exhibiting the higher resolution information. The highest resolution information the instrument is capable of transferring is known as its information limit. With spherical aberration correctors, the point resolution is extended to the information limit and the distinction disappears for most practical purposes.

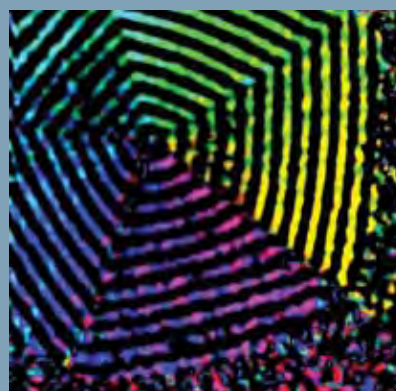

Moiré-fringe image extracted from the original TEM image taken on the spherical-aberration-corrected Tecnai™ F20.

Observing and recording the image

Originally, TEMs used a fluorescent screen, which emitted light when impacted by the transmitted electrons, for real-time imaging and adjustments; and a film camera to record permanent, high resolution images (electrons have the same influence on photographic material as light). The screen was under vacuum in the projection chamber, but could be observed through a window, using a binocular magnifier if needed. The fluorescent screen usually hinged up to allow the image to be projected on the film below. Modern instruments rely primarily on solid-state imaging devices, such as a CCD (charge-coupled device) camera, for image capture. They may still include a fluorescent screen, but it may be observed by a video camera. In this text, unless we are discussing specific aspects of the imaging system, we will simply refer to an imaging device.

The recent introduction of a direct electron detector promises significant improvements in image resolution and contrast, particularly in signal-limited applications. A conventional CCD camera uses a scintillator material over the image detector elements to convert incident electrons to light, which then creates charge in the underlying CCD element. The scintillator introduces some loss of resolution and the conversion process decreases the efficiency with which electrons contribute to image contrast. This can be critical in applications that are sensitive to damage by the electron beam, such as cryogenically prepared samples of delicate biological materials, where it is essential to extract the maximum amount of information from a faint, noisy signal before the sample is destroyed. Eliminating the scintillator with a direct electron detector improves image resolution and increases detector efficiency by up to three times.

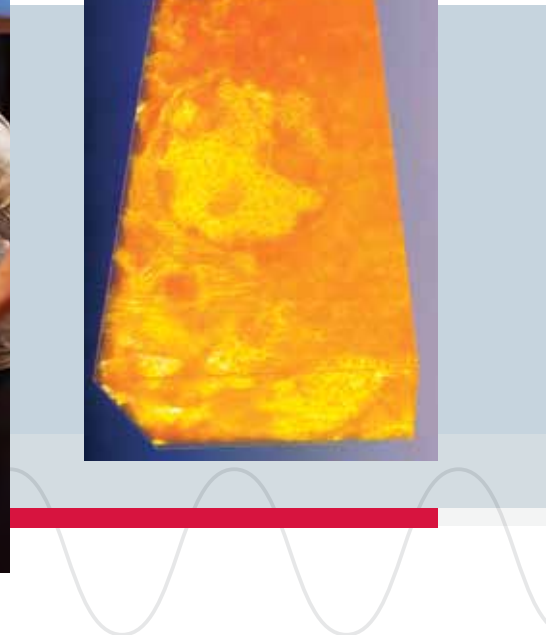
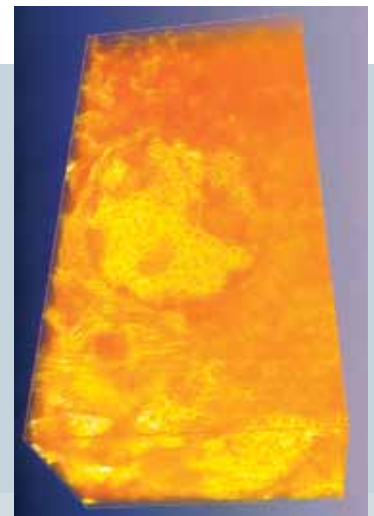
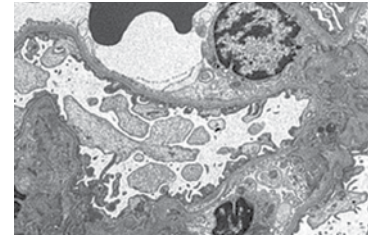

Vacuum

Electrons behave like light only when they are manipulated in vacuum. As has already been mentioned, the whole column from source to fluorescent screen (including the camera) is evacuated. Various levels of vacuum are necessary: the highest vacuum is around the specimen and in the source; a lower vacuum is found in the projection chamber and camera chamber. Different vacuum pumps are used to obtain and maintain these levels. Vacuum in a field emission electron gun may be as high as (i.e., “pressure as low as”) 10^{-8} Pa.

To avoid having to evacuate the whole column every time a specimen or photographic material or a filament is exchanged, a number of airlocks and separation valves are built in. In modern TEMs the vacuum system is completely automated and the vacuum level is continuously monitored and fully protected against faulty operation.

Environmental TEM

Environmental TEM (ETEM) uses a specially designed vacuum system to allow researchers to observe specimens in a range of conditions approaching more “natural” environments, with gas pressures in the sample chamber as high as a few percent of atmospheric pressure. This can be important for observing interactions between the sample and the environment, as for example the action of a solid catalyst particle in a gaseous reaction environment. ETEM relies on pressure-limiting apertures and differential vacuum pumping to permit less restrictive vacuum conditions in the vicinity of the sample while maintaining high vacuum in the rest of the electron column. The size of the sample chamber in a TEM is highly constrained by the requirements of lens design – the sample is actually located inside the objective lens. The development of aberration correctors promises to relax some of these constraints, creating additional flexibility for larger, more complex experimental apparatus in ETEM.



Growth of a multi-wall carbon nanotube from a metal catalyst particle.

Colored Electrons

We see a world full of color. The color we see comes from our eyes' ability to distinguish among various wavelengths of light. However, most electron detectors, see in black and white, or more accurately, shades of gray. What then of the beautiful color images that we see in this publication and elsewhere attributed to electron microscopes? In most cases, color has been added post-imaging for purely aesthetic reasons. There are exceptions. Energy-filtered TEM (EFTEM) creates images from electrons that have been selected for a specific level of energy loss during their passage through the sample. Since energy can be equated to wavelength, color EFTEM images, usually made by combining multiple images acquired at different energy loss settings, are perhaps the closest we can come to color electron images. But even EFTEM images are false color images in the sense that the correspondence between energy loss and color is an arbitrary assignment made by the creator of the image. Color is also used to enhance X-ray maps, where a particular color may be assigned to a particular element to show its distribution in the specimen.

Vacuum

Normal atmospheric air pressure is around 760 mm of mercury. This means that the pressure of the atmosphere is sufficient to support a column of mercury 760 mm high. Physicists use the Pascal (Pa) as the SI unit of pressure, but microscopists often use torr and mbar as well. Normal air pressure = 1 bar = 1000 mbar = 100 000 Pa = 760 torr = 760 mm of Hg. Typical residual pressure in an electron microscope = 2.5×10^{-5} Pa. At this pressure, the number of gas molecules per liter is about 7×10^{12} , and the chance of an electron striking a gas molecule while traversing the column is almost zero.

E
T
E
M

The electronics

To obtain the very high resolution of which modern TEMs are capable, the accelerating voltage and the current through the lenses must be extremely stable. The power supply cabinet contains a number of power supplies whose output voltage or current does not deviate by more than one part in ten million of the value selected for a particular purpose. Such stabilities require very sophisticated electronic circuits.

Improved electron optical design has made possible a number of increasingly complicated electron-optical techniques. This in turn has created the need to simplify instrument operation to allow more users with less specialized training to generate data efficiently and effectively. Digital electronic techniques in general, and microprocessor-based techniques in particular, play an important role in this respect. Modern electron microscopes employ a fast, powerful computer to control, monitor, and record the operating conditions of the microscope. This results in a dramatic reduction in the number of control knobs, compared with earlier models, and a microscope that is easier to use, especially when multiple accessories require simultaneous optimization. Furthermore, it allows special techniques and experiments to be embedded in the instrument so that the operator can carry them out using the same controls. The computer can be attached to a network to allow automatic backups and data sharing.

Specimen orientation and manipulation

The TEM specimen stage must provide various movements to manipulate and orient the sample. X, Y, and Z translation, and tilt are used to move the appropriate region of the sample into the field of view of the microscope. Tilt about a second axis is required to allow precise orientation of crystalline samples with respect to the beam for diffraction studies and analysis along a specific crystallographic orientation or grain boundary. Specialized stages may also provide for heating, cooling, and straining of the specimen for experiments in the microscope.

The basic movements are provided by a goniometer mounted very close to the objective lens; the specimen is typically located in the objective lens field between the pole pieces because it is there that the lens aberrations are smallest and the resolution is highest. The goniometer itself provides motorized X, Y, and Z movement and tilt about one axis. The specimen is mounted near the tip of a rod-shaped holder, which in turn is introduced into the goniometer through an air lock. It is the specimen holder rod that provides the extra tilt axis or the rotation or heating, cooling, or straining with a special holder being needed for each purpose.

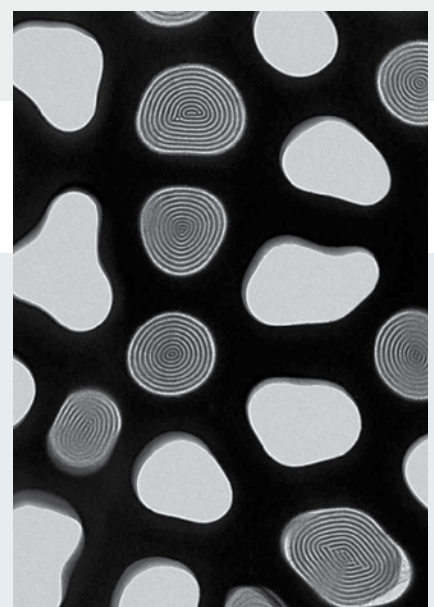

Silica formed within the pores of an alumina membrane.

Specimen preparation

A TEM can be used in any branch of science and technology where it is desired to study the internal structure of specimens down to the atomic level. It must be possible to make the specimen stable and small enough (some 3 millimeters in diameter) to permit its introduction into the evacuated microscope column and thin enough to permit the transmission of electrons. Different thicknesses are required for different applications. For the ultimate high resolution materials studies, the sample cannot be thicker than 20 nm or so; for bio-research, the film can be 300-500 nm thick.

Every branch of research has its own specific methods of preparing the specimen for electron microscopy. In biology, for example, there may be first a chemical treatment to remove water and preserve the tissue as much as possible in its original state, followed by embedding in a hardening resin; after the resin has hardened, slices (sections) with an average thickness of 0.5 μm are cut with an instrument called an ultramicrotome equipped with a glass or diamond knife. The tiny sections thus obtained are placed on a specimen carrier – usually a 3 mm diameter copper specimen grid that has been coated with a structureless carbon film 0.1 μm thick.



Diffraction

When a wave passes through a periodic structure whose periodicity is of the same order of magnitude as the wavelength, the emerging wave is subject to interference, which produces a pattern beyond the object. The same phenomenon can be observed when ocean waves pass through a regular line of posts or when a street lamp is viewed through the fabric of an umbrella. The street lamp appears as a rectangular pattern of spots of light, bright in the center and then getting fainter. This is caused by diffraction of light by the weave of the umbrella fabric, and the size and form of the pattern provide information about the structure (closeness of weave and orientation). In exactly the same way, electrons are diffracted by a crystal, and the pattern of spots on the screen of the microscope gives information about the crystal lattice (shape, orientation and spacing of the lattice planes).



Large Angle Convergent Beam Electron Diffraction (LACBED) pattern from a diamond.

CRYSTAL LATTICE

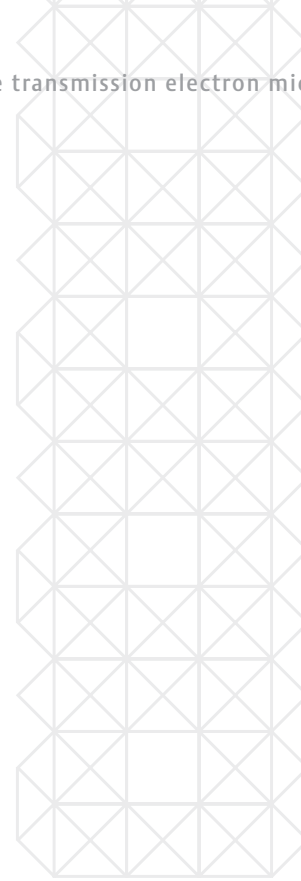

Cryo (freezing) techniques avoid the sample damage unavoidably caused by conventional drying, fixing, and sectioning preparations. However, traditional freezing techniques, while they avoid the introduction of foreign materials, can also damage the sample when the formation of ice crystals destroys delicate biological structures. Vitrification is a rapid freezing process that occurs so quickly water molecules do not have time to crystallize, instead forming a vitreous (amorphous) solid that does little or no damage to the sample structure. The low temperature of the vitrified sample also reduces the damage caused by beam electrons during observations, permitting more or longer exposures at higher beam currents for better quality images.

Cryo TEM allows biological molecules to be examined in their natural context, in association with other molecules that are often key to understanding their form and function. Furthermore, vitrified samples are, quite literally, frozen in time, allowing researchers to investigate time-based phenomena such as the structural dynamics of flexible proteins or the aggregation and dissociation of protein complexes. By measuring the variability within a set of images, each capturing the shape of a molecule at an instant in time, scientists can calculate the range of motion and the intra molecular forces operating in flexible proteins. Similarly, a collection of images might provide a freeze frame sequence of the assembly of a protein complex or conformational changes during antigen binding.

Automated vitrification tools (Vitrobot™) permit precise control of the process, ensuring reliable, repeatable results.

In metallurgy, a 3 mm diameter disc of material (a thickness of approximately 0.3 mm) is chemically treated in such a way that in the center of the disc the material is fully etched away. Around this hole there will usually be areas that are sufficiently thin (approximately 0.1 μm) to permit electrons to pass through. For studies in aberration-corrected systems, this thickness can be no more than a few tens of nanometers.

The use of a focused ion beam to mill and thin a section from a bulk specimen is increasingly important, particularly in semiconductor and other nanoscience applications where the specimen site must be precisely located. See FIB specimen preparation later in this booklet.

vitrobot



Applications specialist preparing the coolant container with liquid nitrogen and loading a sample onto the grid.



Three-dimensional imaging techniques

Understanding the organization of matter in three dimensions has become increasingly important. Semiconductor manufacturers routinely create nanometer scale structures that they must be able to see and measure in order to control their manufacturing processes. Perhaps the most important application of 3D microscopy is in biological sciences where investigators are unraveling the complex molecular interactions that are the basis of life, most of which depend directly upon the intricate three-dimensional shapes of the interacting molecules.

Electron tomography is similar in approach to larger scale medical imaging technologies such as CAT scans and MRI. Tomography acquires a series of projected images from different perspectives as the sample is rotated incrementally about an axis perpendicular to the viewing direction. A computer then combines these images into a three-dimensional model of the sample. It is similar to the way you would turn an object about in your hand while you look at it to appreciate its three-dimensional shape. Electron tomography has been limited by the inability to acquire information from perspectives that lie close to the plane of the thin sample where the beam's trajectory through the sample becomes excessively long – called the missing wedge. The development of dual axis tomography, in which the sample is also rotated about a second axis perpendicular to the first, has improved results – reducing the missing wedge to a missing pyramid. Tomography looks at a single instance of the subject structure, which allows it to analyze differences within a population of such structures, but also limits the analysis to the data that can be acquired from that single sample (often a biological entity quite vulnerable to beam damage). Currently, the best spatial resolution available from tomographic analysis is a few nanometers.

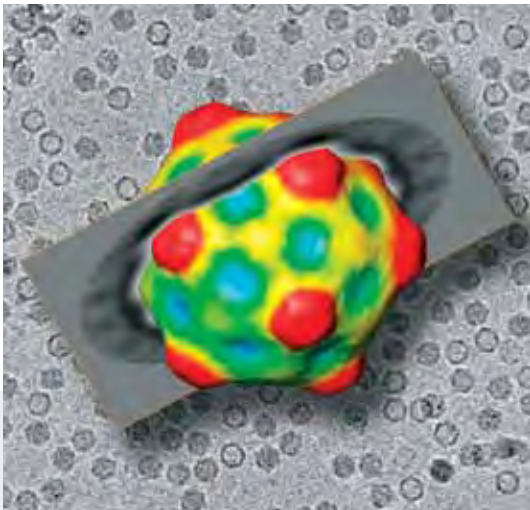

3D model of Cow Pea Mosaic Virus.

Single particle analysis (SPA – a somewhat misleading name) acquires images of a large number of arbitrarily oriented, nominally identical particles and uses a computer to sort them into categories of similar orientation, create composite projected images representative of each orientation, and combine the composited images into a 3D model. By combining multiple images, SPA builds contrast and improves the signal-to-noise ratio of the resulting model. In theory it could continue improving by simply increasing the number of images, though the diminishing returns from incremental increases impose a practical limit. SPA results have been reported with spatial resolution of a few tenths of a nanometer.

Automation plays an important role in both approaches to 3D imaging. In tomographic analysis the entire acquisition of the tomographic series can be automated. Automation is practically indispensable in SPA, which may require the analysis of tens of thousands of particles. In both cases, automation can also help to reduce sample damage by ensuring consistent use of low dose methodologies. Low dose imaging refers to techniques used to minimize the exposure of the sample to damaging radiation from the electron beam. It is essential in 3D analysis (particularly of biological materials) to ensure that the maximum amount of information is obtained before the sample is damaged or destroyed.

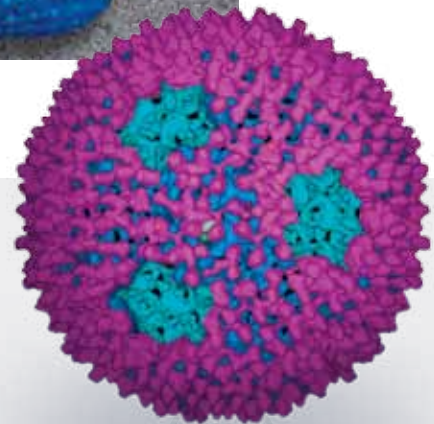

3D IMAGING

The Scanning Electron Microscope

A scanning electron microscope, like a TEM, consists of an electron optical column, a vacuum system, electronics, and software. The column is considerably shorter because the only lenses needed are those above the specimen used to focus the electrons into a fine spot on the specimen surface. There are no lenses below the specimen. The specimen chamber, on the other hand, is larger because the SEM technique does not impose any restriction on specimen size other than that set by the size of the specimen chamber.

The electron gun at the top of the column produces an electron beam that is focused into a fine spot as small as 1 nm in diameter on the specimen surface. This beam is scanned in a rectangular raster over the specimen and the intensities of various signals created by interactions between the beam electrons and the specimen are measured and stored in computer memory. The stored values are then mapped as variations in brightness on the image display. The secondary electron (SE) signal is the most frequently used signal. It varies with the

topography of the sample surface much like an aerial photograph: edges are bright, recesses are dark. The ratio of the size of the displayed image to the size of the area scanned on the specimen gives the magnification. Increasing the magnification is achieved by reducing the size of the area scanned on the specimen. Because the image in modern SEMs is created in a computer, it can be readily transferred to a hard drive or other medium for long-term storage.

SEM

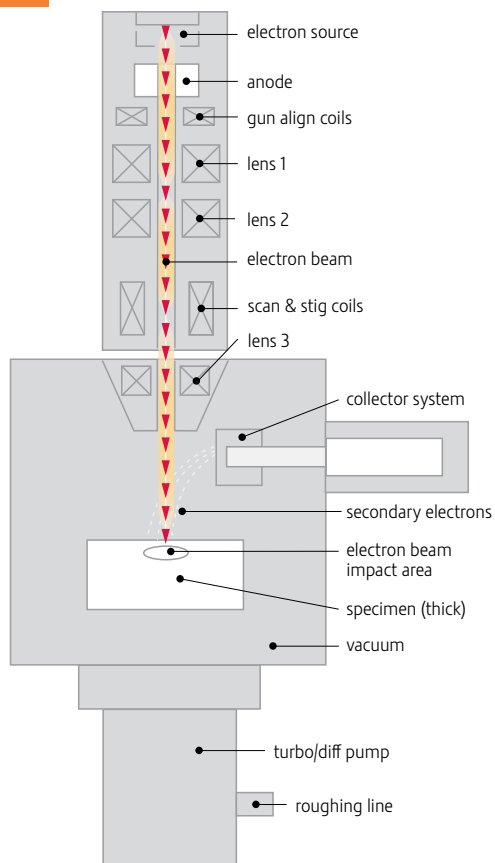

Automotive light bulb analysis to determine failure, imaged on an SEM.

SEM

The electron gun and lenses are similar to those described previously for TEM.

The most important differences between TEM and SEM are:

- Rather than the broad static beam used in TEM, the SEM beam is focused to a fine point and scanned line by line over the sample surface in a rectangular raster pattern.
- The accelerating voltages are much lower than in TEM because it is no longer necessary to penetrate the specimen; in a SEM they range from 50 to 30,000 volts.
- The specimen need not be thin, greatly simplifying specimen preparation.

The interactions between the beam electrons and sample atoms are similar to those described for TEM:

- The specimen itself emits secondary electrons.
- Some of the primary electrons are reflected backscattered electrons (BSE). These backscattered electrons can also cause the emission of secondary electrons as they travel through the sample and exit the sample surface.
- The specimen emits X-rays.
- Electrons are absorbed by the specimen.
- The specimen sometimes emits photons of visible light (cathodoluminescence).
- If the sample is thin, the SEM may be operated in STEM mode with a detector located below the sample to collect transmitted electrons.

All these phenomena are interrelated and all of them depend to some extent on the topography, the atomic number and the chemical state of the specimen. The most commonly imaged signals in SEM are SE and BSE. SE, because of their very low energies, can escape the sample to be detected only if they originate very close to the sample surface. This gives SE images high spatial resolution and strong topographic contrast. The BSE signal is used primarily for its strong atomic number contrast. Characteristic X-rays are also widely used in SEM for elemental microanalysis.



Sperm tails tangled up in a seminiferous tubule, magnified 600x on an FEI Quanta™ scanning electron microscope.

Electron Interactions with Matter

In the modern view of matter, an atom consists of a heavy charged nucleus surrounded by a number of orbiting electrons. The number of electrons is equal to the number of protons in the nucleus and is known as the atomic number of the atom. The incoming beam electron can interact with the nucleus and be backscattered with virtually undiminished energy (just as a space probe is deviated by the gravity of a planet during a fly-by). Or it can interact with the orbiting electrons of sample atoms in a variety of ways, giving up some of its energy in the process. Each type of interaction potentially constitutes a signal that carries information about the sample. For instance, the most frequent interaction is the ejection of an electron from the atom with relatively low energy, a few eV. If this occurs near the sample surface, the liberated electron may escape and be detected as a secondary electron. Other signals include characteristic X-rays, cathodoluminescence, absorbed current and more, each carrying a specific type of information.



microanalysis

Electron detection

Detectors for backscattered electrons and secondary electrons are usually either a scintillation detector or a solid-state detector. In the scintillator case, electrons strike a fluorescent screen, which emits light, that is amplified and converted into an electrical signal by a photomultiplier tube. The solid-state detector works by amplifying the minute signal produced by the incoming electrons in a semiconductor device. A third type of detector monitors the net current absorbed by the specimen (beam current less secondary and backscattered electron emission) or the current induced in a semiconductor junction by the incoming beam electron. These absorbed current and EBIC (electron beam induced current) measurements permit the study of dynamic electrical phenomena in electronic devices.

Observation and recording of the image

As with TEM, most modern SEMs have migrated from photographic film to digital media for image recording and storage.

Resolution

Resolution in a SEM depends on the degree to which the signal, at any instant in time, can be associated with the position of the electron beam; specifically, for a particular beam location, how large is the region within the sample from which the signal originates. This can be affected by a number of factors, including the type of signal, the size of the spot formed by the beam, composition of the sample, the energy of the beam, and more (a detailed discussion of all of these is beyond the scope of this book). Generally, at lower voltages, where the beam electrons do not travel far into the sample, the size of the spot is the primary determinant of image resolution. At higher voltages, the volume of interaction, from which the signal originates, may become the primary consideration. Currently, the best SEMs offer resolution below 1 nm to below 1 kV up through the full range of accelerating voltages, allowing the operator to choose beam energy to suit the needs of the analysis; for example, higher energy to provide a wide energy spectrum for X-ray analysis, or lower energy to enhance surface specificity or avoid charging and beam damage.

Beam deceleration

Beam deceleration provides additional flexibility in the choice of accelerating voltage. With beam deceleration, the beam traverses most of the column at high energy to reduce the adverse effects of chromatic aberration, and is then decelerated by an opposing electrical potential applied to the sample, so that beam electrons land with reduced energy.

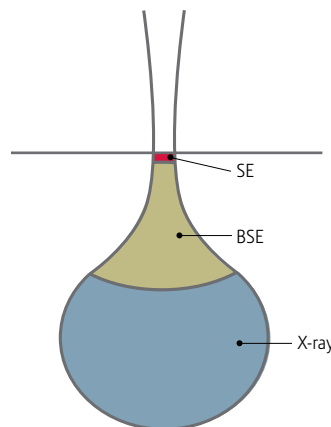

Fig. 7 Different types of signal originate from different volumes of interaction. The size and shape of the volume depends on many factors, including accelerating voltage and sample composition. The SE signal generally has the smallest interaction volume and, potentially, the highest resolution. X-rays and BSE can originate from much larger volumes (also creating SE as they exit the sample). The thin samples used in STEM eliminate much of the volume, allowing very high resolution even with X-rays and BSE.



A segment of a butterfly wing imaged using an SEM.

Resolution and Accelerating Voltage, Spot Size, and Volume of Interaction

The resolution of a SEM is determined by the size of the region from which the signal originates. Certainly this will not be smaller than the extent of the spot illuminated by the beam on the sample surface. In conventional SEM, it is easier to form a smaller spot at higher beam energies because the degrading effects of chromatic aberration are relatively less significant. However, at higher beam energies, the beam electrons penetrate deeply and scatter widely within the sample, contributing signal from locations well outside the spot and thus degrading image resolution. When beam energy is reduced in a conventional SEM, spot size increases as the fixed energy spread among electrons in the beam becomes larger relative to the nominal

beam energy, and the adverse effects of chromatic aberration increase. At some point the benefit of reducing penetration is overwhelmed by the cost of increasing spot size.

A monochromator reduces the energy spread of the beam by eliminating beam electrons that fall outside a selected range. Combined with a field emission electron gun, monochromator equipped SEMs have demonstrated sub-nanometer resolution at accelerating voltages below 1 kV. Monochromator technology avoids restrictions on sample type and size that have limited the utility of other approaches to low voltage imaging, such as “in-the-lens” configurations and chromatic aberration correctors.

The decelerating field also acts as an additional lens field, further improving contrast and resolution. The ability to manipulate beam energy and landing energy independently has allowed scientists to investigate interesting new contrast mechanisms and resulted in spectacular images at landing energies as low as 50 eV.

Image treatment

Because the image in a SEM is completely electronically produced, it can be subjected to sophisticated analysis and manipulation using modern digital techniques. This includes contrast enhancement, inversion (black becomes white, etc.), filtering, mixing of images from various detectors, subtraction of the image from one detector from that produced by a different detector, color coding, and image analysis. The application of these techniques must be guided by the primary goal of extracting the best possible information from the specimen.

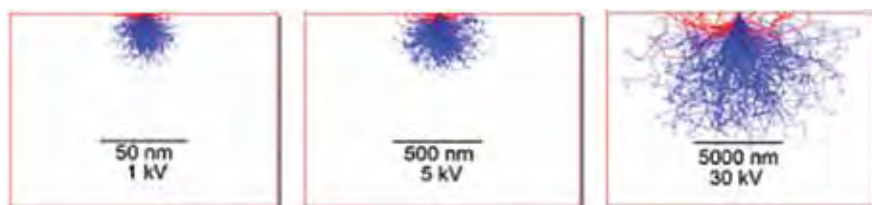
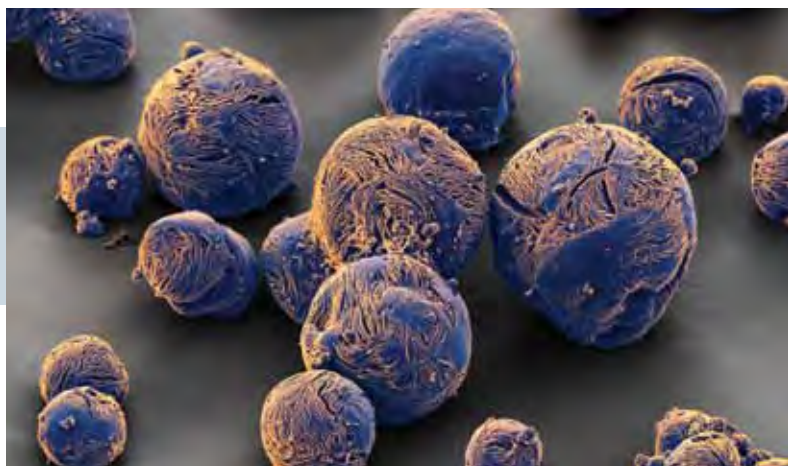

Fig. 8 Volume of interaction vs accelerating voltage. The blue tracks show primary electron trajectories that terminate in the sample. The red tracks are primary electrons that ultimately escape from the sample as BSE. BSE can exit the sample surface far from the beam spot potentially creating SE (type II) that degrade the resolution of the SE signal.



SEM Magnification

SEM magnification equals simply the length of one line scanned in the image (usually the width of the image) divided by the length of the line scanned on the sample surface (usually the width of the raster pattern). A high resolution computer display might be half a meter wide and display 2000 pixels over that distance (pixel width = .25 mm). If each pixel represents one square nanometer on the sample surface, then an image that fills the display represents a scanned area 2000 nm (2 μ m) wide and the magnification of the image on the display is 250,000x.

Environmental Chamber

The pressure-temperature phase diagram for H₂O indicates that true “wet” conditions only exist at pressures of at least 600 Pa at 0°C (environmental microscopists usually refer to 4.6 torr = 4.6 mm of mercury). In the range 650 to 1300 Pa (5-10 torr) therefore, the specimen may be observed while at equilibrium with water.

Vacuum

In general a sufficiently good vacuum for a SEM is produced by either an oil diffusion pump or a turbomolecular pump (the current standard for most SEMs), in each case backed by a mechanical prevacuum pump. These combinations also provide reasonable exchange times for specimen, filament, and aperture (less than a few minutes). Vacuum airlocks may also be used for large chambers and in high volume applications when fast sample exchange has high value. Modern SEM vacuum systems are fully automatically controlled and protected against operating failures.

Samples for conventional SEM generally have to be clean, dry, vacuum-compatible and, ideally, electrically conductive. In recent years the environmental scanning electron microscope (ESEM) has expanded the range of samples and sample environments that can be accommodated in the SEM chamber. Examples of specimens that pose problems are wool or cotton tissue, cosmetics, fats and emulsions (e.g., margarine).

Early attempts to view a specimen containing volatile components by placing it in an environmental chamber isolated from the main column vacuum by small, differential pumping apertures were hampered by the inability of conventional secondary electron detectors to work in a non-vacuum or low vacuum environment. The ESEM's gaseous secondary electron detector uses gas molecules in the sample environment in a cascade amplification (see Fig. 9) to detect and amplify the secondary electron signal while at the same time producing positive ions, which effectively suppress charging artifacts as they are attracted by any negative charge accumulating on insulated specimen surfaces.

Variable pressure and low pressure are terms used to describe SEMs that operate in an intermediate vacuum range between high vacuum SEM and ESEM. These instruments provide some of the sample flexibility of ESEM, though they are not generally capable of providing pressure/temperature conditions that will sustain liquid water.

Application and specimen preparation

A SEM can be used whenever information is required about the surface or near-surface region of a specimen. It finds application in almost every branch of science, technology, and industry. The only requirement is that the specimen must be able to withstand the vacuum of the chamber and bombardment by the electron beam. Because there is no requirement for a thin sample, the preparation of specimens to be investigated by SEM is considerably simpler than the preparation of specimens for TEM.

Many specimens can be brought into the chamber without preparation of any kind. If the specimen contains any volatile components such as water, they must be removed by a drying process (or in some circumstances it can be frozen solid) before they can be used in a high vacuum system. Non-conducting specimens will accumulate charge under electron bombardment and may need to be coated with a conducting layer. Iridium gives a fine grained coating and is easily applied in a sputter coater. It gives a good yield of secondary electrons, and consequently, a good quality image of the surface. Iridium gives a fine grain coating and is easily applied in a sputter coater. Carbon is an alternative when the X-ray emissions from iridium might interfere with elemental analysis. The layer itself must be thick enough to provide a continuous conductive film, but also not so thick as to obscure surface details of interest – typical thicknesses are in the range 1-10 nm depending on the sample and application.

Sometimes it is very important to avoid any alteration of the sample during preparation, for example, forensic specimens, silicon wafers examined during the IC manufacturing process, and integrated circuits, which need to be studied while in operation. In such cases special techniques, such as low voltage SEM, are used to avoid charging without the use of conductive coatings. Cryo preparations are also used in SEM, particularly in biological applications or organic materials (polymers).



Using carbon paint to prepare sample for mounting.



Mounting sample to stub.

Specimen orientation and manipulation

The quality of the image in a SEM depends on the orientation and distance of the specimen from the detectors and the final lens. The specimen stage allows the specimen to be moved in a horizontal plane (X and Y directions), up and down (Z direction), rotated, and tilted as required. These movements are generally motorized and controlled by a computer using a joystick or mouse.

The various SEM models in a range differ in the size of their specimen chambers, allowing various sizes of specimens to be introduced and manipulated. The maximum specimen size also determines the price because the larger the specimen chamber, the larger the stage mechanism needed to move and manipulate the sample and the larger the pumping system needed to obtain and maintain a good vacuum.

The simplest models accept specimens of a few centimeters in diameter and can move them 50 mm in the X and Y directions. Larger models can accommodate samples up to 300 mm in diameter. Most models also allow samples to be tilted to high angles and rotated through 360 degrees.

There are special stages or attachments for heating, cooling, and straining specimens, but because of the wide variety of possible sample sizes, these stages are often produced by specialist firms.

If the specimen in a SEM is thin enough to transmit electrons, a detector positioned below the specimen may be used to collect these electrons, providing STEM capabilities similar to those described previously for TEM. The lower accelerating voltages and lack of post-specimen lenses limit the ultimate resolution and flexibility of SEM-based STEM. Nonetheless, it can be a powerful technique, extending the resolution and contrast capabilities seen in SEM imaging of bulk samples, and improving the spatial resolution of X-ray microanalysis by reducing the large volume of interaction from which X-rays can originate in bulk specimens.

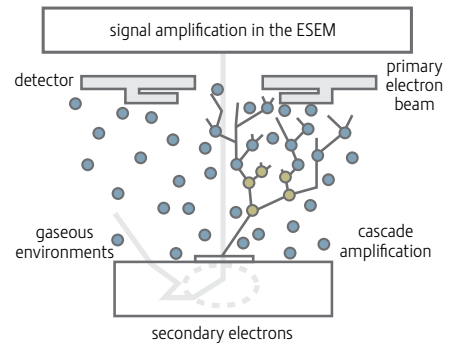
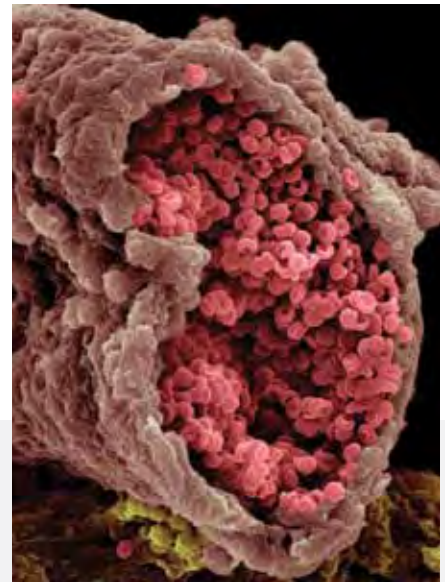

Fig. 9 The ESEM's Gaseous Secondary Electron Detector uses cascading ionization among the residual gas molecules in the sample chamber to amplify the secondary electron signal and neutralize any charge that accumulates on the surface of insulating samples.



Artery with red blood cells.

SPECIMEN PREPARATION



SEM chamber and stage.



Scanning Transmission Electron Microscopy

Scanning transmission electron microscopy combines the principles of TEM and SEM and can be performed on either type of instrument. Like TEM, STEM requires very thin samples and looks primarily at beam electrons transmitted by the sample. One of its principal advantages over TEM is in enabling the use of other of signals that cannot be spatially correlated in TEM, including secondary electrons, scattered beam electrons, characteristic X-rays, and electron energy loss. While the technique can be used in both a SEM and TEM, the higher accelerating voltages available in a TEM allow the use of thicker samples, and the additional lenses below the sample greatly expand the number of possibilities for gathering information. TEM-based STEM using a condenser lens aberration corrector has achieved a resolution of 0.05 nm.

Like SEM, the STEM technique scans a very finely focused beam of electrons across the sample in a raster pattern. Interactions between the beam electrons and sample atoms generate a serial signal stream, which is correlated with beam position to build a virtual image in which the signal level at any location in the sample is represented by the gray level at the corresponding location in the image. Its primary advantage over conventional SEM imaging is the improvement in spatial resolution, which results from eliminating the electron scattering that occurs in bulk specimens as the beam electrons penetrate into the sample.

Secondary electrons (SE) are not often used in STEM mode but are mentioned here for completeness. SE is the primary imaging signal in SEM where they provide good spatial resolution and high topographic sensitivity. SE are electrons from sample atoms that have been scattered by beam electrons. SE have very low energies and can escape from the sample only if they originate very close to the surface.

Scattered beam electrons. Beam electrons may be elastically scattered by the nuclei of sample atoms. In a bulk specimen in a SEM, elastically scattered beam electrons that have been directed back out of the sample constitute the backscattered electron (BSE) signal. In STEM, transmitted beam electrons that have been scattered through a relatively large angle are detected using a high angle annular dark field (HAADF) detector. In both cases, BSE and HAADF, the signal intensity is a function of the average atomic number of the sample volume that interacted with the beam, thus providing atomic number contrast (Z-contrast) in the image.

X-ray microanalysis. Electrons bombarding the specimen cause it to emit X-rays whose energy is characteristic of the elemental composition of the sample. X-ray microanalysis uses an energy dispersive X-ray (EDX) spectrometer to count and sort characteristic X-rays according their energy. The resulting energy spectrum exhibits distinctive peaks for the elements present, with the peak heights indicating the elements' concentrations. Analysis of the spectrum can determine precise elemental concentration with a spatial resolution down to the 100 nm scale in bulk SEM specimens and 10-20 nm in thin specimens in SEM-based STEM. Sub-Ångstrom spatial resolution has been reported for X-ray microanalysis in TEM-based STEM. Because of the very small volume analyzed at any given instant, X-ray microanalysis can detect very small quantities of elements (down to one thousandth of a picogram (10^{-12} g) or less). It is particularly useful for detecting locally concentrated occurrences of elements that are present at very low bulk concentrations, such as grains of precious metal ores.

The primary limitations on the speed and precision of X-ray analysis are the fraction of outgoing X-rays that can be collected, the speed with which X-rays can be detected and measured, and the energy resolution of the detector. That rate at which a single detector can analyze X-rays has been increased significantly by the development of silicon drift detectors. Custom-designed systems, optimized for rapid elemental analysis in applications such as SEM-based automated mineralogy, may also use multiple detectors to increase the total area of the detectors, and thus the number of X-rays they intercept. Adding detectors is a significant design problem because the detectors must be positioned close to the specimen without interfering with other functions of the microscope. TEMs specifically optimized for X-ray

analysis (FEI's Tecnai Osiris™) have achieved collection of solid angles approaching 1 steradian, significantly improving minimum detectable mass performance. Therefore, offering the capability to extract more information from the sample in a shorter time, a key factor when looking at samples that may change or damage under the electron beam, and also reducing the time needed to form elemental maps from samples.

Wavelength dispersive X-ray (WDX) spectrometry measures and counts X-rays by their wavelength (a correlate of energy). A wavelength spectrometer uses a crystal or grating with known spacing to diffract characteristic X-rays. The angle of diffraction is a function of the X-ray wavelength and the crystal is mechanically scanned through a range of angles while a detector measures varying intensity. WDX is generally much slower than EDX, but offers higher spectral (energy) resolution (which helps to avoid inferences among closely spaced spectral peaks) and better sensitivity to light elements. WDX spectrometers are larger than EDX spectrometers and several are required with different crystals to cover the full range of elements. Their size generally limits their application to SEM or dedicated electron probe instruments.

Electron energy loss spectrometry (EELS) analyzes transmitted electrons to determine the amount of energy they have lost in interactions with the sample. It provides information about the interacting atoms, including elemental identity, chemical bonding, valence and conduction band electronic properties, surface properties, and element-specific pair distance distribution functions. EELS is principally used with TEM-based STEM.

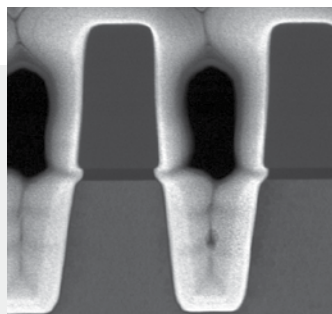
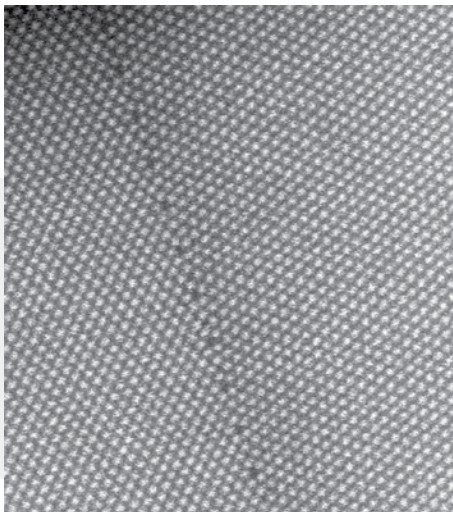

STEM



X-ray Analysis

The impinging electrons in the primary beam may eject an electron from a sample atom. If the ejected electron originates from one of the inner orbitals, the resulting vacancy may be filled by an electron from an outer orbital of the same atom with the concurrent emission of an X-ray. The energy of the emitted X-ray is equal to the energy difference between the orbitals and is thus “characteristic” of the elemental identity of the emitting atom. An X-ray spectrometer

counts and measures the energy of emitted X-rays. The relative intensity of the X-ray signal at each energy (the energy spectrum) can be used to calculate the quantitative elemental composition of the sample within the volume of interaction – the region within the sample from which the X-ray signal originates as the beam electrons penetrate and scatter.

Focused Ion Beam Systems and DualBeam™ Systems

So far this booklet has been about electron microscopy and the useful information that can be obtained using an electron beam. However, electrons are not the only charged particles that can be accelerated and focused using electric and magnetic fields. It was explained earlier that the atom consists of a positively charged nucleus surrounded by electrons in orbits. Normally the atom is neutral because there are equal numbers of protons and electrons. An atom that has lost one or more of its outermost electrons has a positive charge and can be accelerated, deflected, and focused similarly as its negatively charged cousin, the electron. The most important difference lies in the mass of the ions. The lightest ion has almost 2000 times the mass of an electron and heavier ions can be another 250 times as massive. In a SEM, the relatively low-mass electrons interact with a sample non-destructively to generate secondary electrons which, when collected, provide high quality image resolution down to the sub-nanometer range. A focused ion beam (FIB) instrument is almost identical to a SEM, but uses a beam of ions rather than electrons. The higher-mass ions dislodge neutral and charged particles (atoms, molecules, and multi-molecular particles) from the sample surface in a process called sputtering. Ionized specimen atoms and molecules are called secondary ions, which can be used for imaging and compositional analysis. Ion bombardment also creates secondary electrons that can be used for imaging, just as they are in a SEM.

The ion beam directly modifies or “mills” the surface, via the sputtering process, and this milling can be controlled with nanometer precision. By carefully controlling the energy and intensity of the ion beam, it is possible to perform very precise nano-machining to produce minute components or to remove unwanted material. In addition, ion beam assisted chemical vapor deposition can be used to deposit material with a level of precision similar to FIB milling. A small quantity of a specifically selected precursor gas is injected into the vicinity of the beam, where it is decomposed by the beam, depositing the nonvolatile decomposition products on the specimen surface while the volatile products are extracted by the vacuum system. Other reactive gases can be used with the ion beam, which, depending on the particular gas and substrate, can improve the milling rate, increase the milling selectivity for specific materials, or suppress the redeposition of milled material.

A FIB becomes even more powerful when it is combined with a SEM as in the FEI DualBeam™ system. In a DualBeam, the electron and ion beams intersect at a 52° angle at a coincident point near the sample surface, allowing immediate, high resolution SEM imaging of the FIB-milled surface. Such systems combine the benefits of both the SEM and FIB and provide complementary imaging and beam chemistry capabilities.

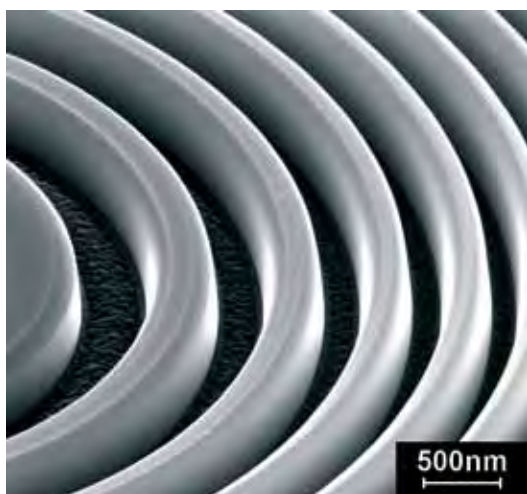

Fresnel lens milled into silicon using FIB prototyping technology.



FIB-cut in steel v2a EE by 1nA to IB milling-002 steel.

Ion column

FIB columns must provide a beam of energetic ions for use in all three application categories: imaging, analysis, and sample modification. High-resolution imaging requires small spot sizes with low currents. Analysis requires higher currents to generate enough signal for precise measurement. Sample modification requires a range of beam currents, from the very lowest for precise spatial control, to the very highest for high material removal rates. Low energy final polishing to remove the amorphous and/or ion-implanted damage layer left by higher energy milling is also an important capability. Over the entire range of applications, higher beam current to spot size ratios generally improve system performance.

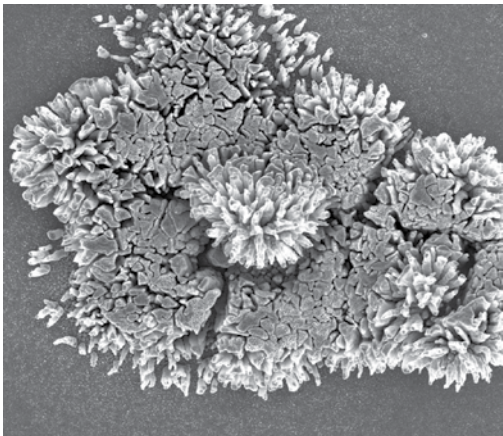

Spontaneous growth of doped ZnO coral during pulsed laser deposition.



A FIB's liquid metal ion source (LMIS).

Ion source

Most FIBs use a liquid metal ion source (LMIS) to provide charged ions for the beam. Other types of sources may be used in special applications, such as those requiring very high beam currents for fast milling. The LMIS consists of a sharply pointed tungsten needle coated with a liquid metal. Gallium provides the best combination of low vapor pressure, large atomic number, and ease of use. A wire, welded to the needle, holds the needle in position and heats it to burn off contamination. A coiled wire below the needle holds a reservoir of gallium to replenish the coating. The needle points toward an aperture in a negatively biased extraction electrode. The field created by the extraction electrode accelerates ions from the needle tip through the aperture. The extraction field is very strong at the sharply pointed needle tip. In this field the liquid gallium coating flows into an even more sharply pointed cone. A balance between electrostatic and surface tension forces determines the shape of this



cone, known as a Taylor cone. If the apex of the cone were to become perfectly sharp, the extraction field would be infinitely strong. At some point as the cone develops, the field becomes strong enough to ionize gallium atoms at its apex. The ion density is very high near the tip and the ions exert significant Coulomb forces on each other. As they accelerate away from the tip in the extraction field, they spread out and their coulombic interactions diminish. This process removes gallium from the tip and reduces its sharpness. Thus a balance exists at the tip of the cone between the removal of gallium, through ionization, and the replenishment of gallium, through fluid flow into the tip region. These forces actually create a protrusion, or jet, at the tip of the cone. The jet is very small, having a radius of perhaps five nanometers. The ion trajectories out of the jet lie mostly within twenty to thirty degrees of the needle axis. Even with a low total emitted current, about one microamp, the small source size and narrow emission angle give the LMIS a brightness of more than a million amperes per square centimeter per steradian.

When the FIB column is optimized for image resolution (i.e., small spot size, low beam current, and small apertures), the spherical aberrations of the column lenses are greatly reduced and system performance is limited by certain characteristics of the source, namely, its apparent size and energy distribution. Though the radius of the ion jet is only a few nanometers, its apparent size (i.e., the radius of the region from which the ions appear to originate when their trajectories are plotted backward through the optical system) is larger by a factor of ten, approximately 50 nanometers. This apparent source is the object that the optical system must demagnify onto the sample surface. The enlargement of the apparent source is largely due to perturbations in particle trajectories caused by coulombic interactions between ions. These same interactions cause an increase in the energy spread of the ions. Increased energy spread results in increased chromatic aberration throughout the optical system. Ideally, the beam should have a Gaussian intensity profile. In practice, beam tails extend many times the full-width-half-maximum diameter of the beam. These tails can be attributed to the transverse energy spread resulting from coulombic interactions. Thus, apparent source size, energy distribution, and beam shape are all affected adversely by space charge effects in high current density beams. Anything that increases the current density near the emitter tip

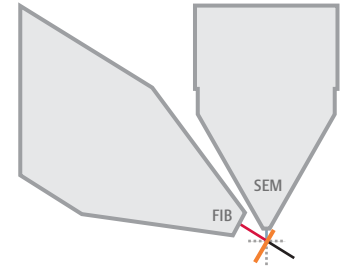

Fig. 10 In a DualBeam™ the electron and ion beams intersect at a 52° angle at a coincident point near the sample surface, allowing immediate, high resolution SEM imaging of the FIB-milled surface.

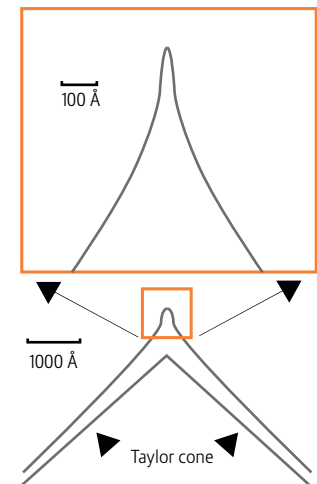

Fig. 11 Under the influence of a strong electric field, the liquid metal forms an even more sharply pointed cone at the tip of the electrode. The shape of the cone is maintained by the balance between escaping ions at its tip and the flow of liquid from the reservoir.

Space Charge Effects

Modern high-brightness ion and electron sources generate beams of very high current density. In these beams particles may interact with one another through their individual electric fields. Space charge effects are generally more troublesome for ion columns because, given the same accelerating voltage, ions, which are much more massive than electrons, will acquire much lower velocity and traverse the column with much less distance between particles. These coulombic interactions operate through three distinct mechanisms. The average

space charge acts like a diverging lens and may be corrected by focal adjustments. The Boersch effect results when a particle is accelerated by another particle behind or decelerated by a particle ahead. The net result is an increase in the beam energy spread and chromatic aberration. Trajectory displacement occurs when particles are close enough to exert lateral forces on each other.

increases the space charge effects and degrades performance. For this reason LMISs are always operated at the lowest possible total emitted current. Minimization of space charge effects, through a careful balance of electrode geometry and field strength, is the primary concern in the design of modern high-intensity LMIS. A higher extraction field and larger extractor-electrode spacing reduces the time the ions spend in the high interaction zone of the ion jet and still maintains a low level of total emission current.

From a practical point of view, the gallium supply of the LMIS is consumed during use and so the source must be replaced periodically. Similarly, the various beam-limiting apertures in the column will be eroded by the ion beam and so also require periodic replacement. Source lifetime and ease of replacement are important considerations. Lifetime depends on the size of the liquid metal reservoir; however, larger reservoirs increase the overall size of the source, making the source more difficult to integrate into the column design as an easily replaceable module. Current generation FEI ion sources have lifetimes in excess of 1000 hours and exchange times, including system pump-down, of less than four hours. FEI has also developed a removable source-end structure that makes source replacement in the field fast and easy.



Saintpaulia ionantha pollen on blossom structures.

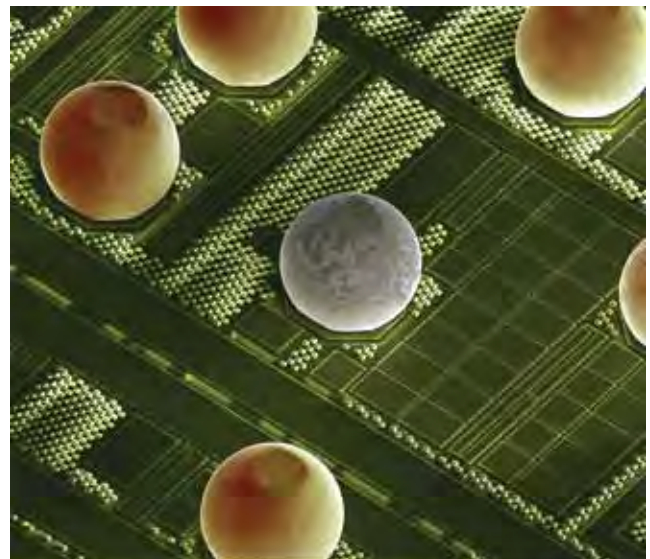

Top-down view of ALU bumps on top of the last metal layer of an integrated circuit.

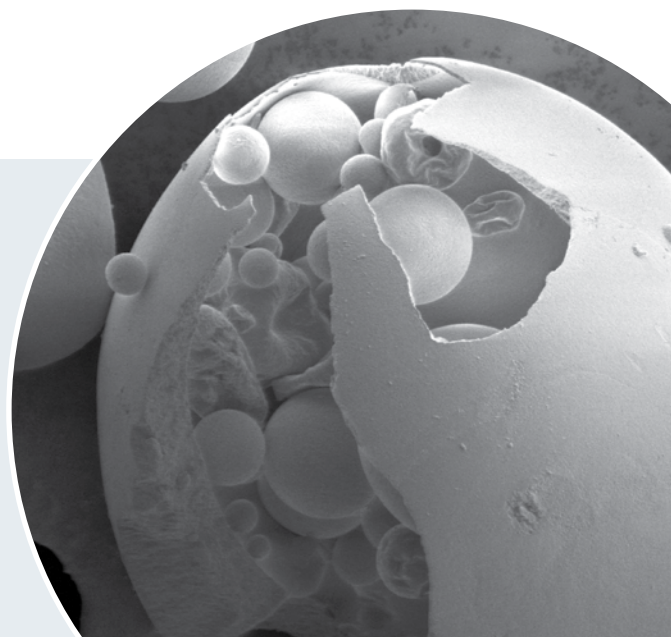

Applications

Life sciences

Electron microscopy is being used today in research laboratories around the world to explore the molecular mechanisms of disease, to visualize the 3D architecture of tissues and cells, to unambiguously determine the conformation of flexible protein structures and complexes, and to observe individual viruses and macromolecular complexes in their natural biological context.

Structural biology – 3D techniques, electron tomography and single particle analysis, allow researchers to derive important information regarding protein domain arrangements and, in some cases, to trace individual polypeptide chains. The combination of electron microscopy reconstruction with X-ray crystallography and NMR spectroscopy enables even greater structural detail by fitting atomic scale structural models into the EM density map.

Cellular biology – High-resolution cryo microscopy avoids the alterations caused by conventional preparation techniques to allow imaging of cell membrane structures and sub-cellular morphology in fully hydrated conditions.

Tissue biology – An electron microscope's ability to provide high resolution ultrastructural imaging over large areas and volumes of tissues or cells is invaluable in discerning critical relationships among components of biological systems across large differences in spatial scale.

Biomaterials – The properties of biomaterials and nanoparticles are highly dependent on structural characteristics that are readily observed using electron microscopy.

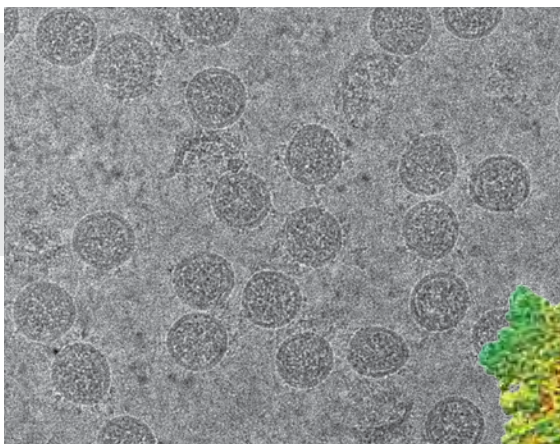

BIOLOGY

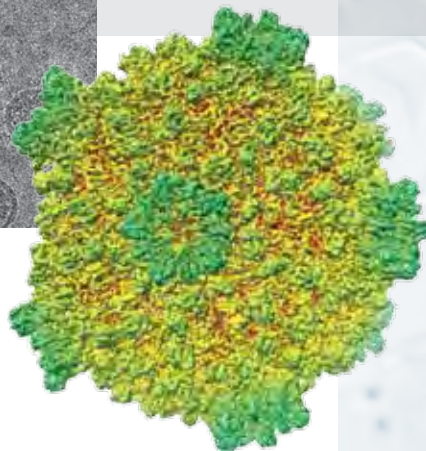

Electronics

In laboratories and production facilities for semiconductor, solar, micro-electro-mechanical system (MEMS) labs, and data storage devices, electron and ion microscopy provide the high resolution imaging and analysis required to develop and control manufacturing processes.

Circuit edit – Engineers use a FIB's precise milling and material deposition to rewire integrated circuits to check design modifications without having to repeat the lengthy and expensive manufacturing process.

Failure analysis – The DualBeam's ability to cross-section subsurface defects and quickly prepare site-specific thin section sample for high resolution imaging in S/TEM allows engineers to determine the root causes of manufacturing defects.

Metrology and process control – As the dimensions of microelectronic devices have shrunk beyond the resolving power of optical microscopes (and in some cases, beyond that of SEM as well), S/TEM provides critical feedback needed to control manufacturing processes.

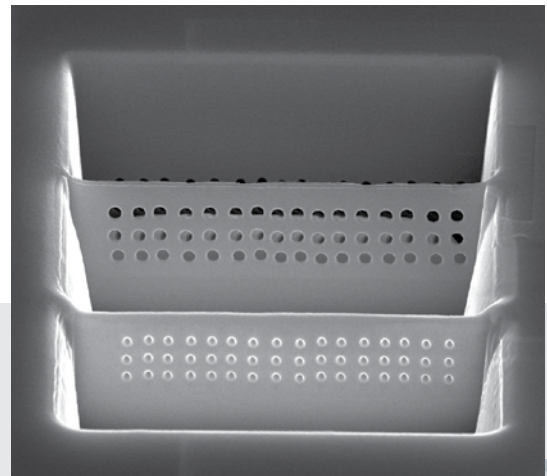

INTEGRATED CIRCUITS

Industry

Natural resources – Mining companies use automated electron microscopy to analyze millions of micro-scale features in an automated, objective, quantitative, and rapid manner. The results compliment bulk chemical assays and together they are used to maximize metal recovery and guide decisions in exploration, mining, mineral processing, and metal refining. In oil and gas exploration similar analyses provide quantitative lithotype and porosity characteristics of reservoir, seal, and source rocks. The results enhance and validate seismic, wireline, and mud logs, providing input into geological models and reducing risk in exploration and extraction.

Forensics – Forensic science uses electron microscopy to analyze criminal evidence such as gunshot residue, clothing fibers, handwriting samples, and soil.

Other automated particle analysis – Inorganic particles – both natural and manmade – including soil, coal, cement, fly ash, and airborne dust, can be analyzed to provide a more detailed understanding of the impact of waste and pollution on the environment and health.

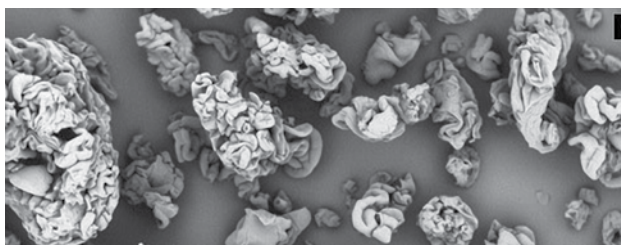

Research

Electron microscopes are being applied successfully in the pursuit of a deeper understanding of the structure-property-function relationships in a wide range of materials and processes such as next generation fuel cell and solar cell technologies, catalyst activity and chemical selectivity, energy-efficient solid-state lighting; and lighter, stronger, and safer materials.

3D nanocharacterization – Nanocharacterization moves to a new level with STEM, TEM, and DualBeam tomography affording 3D visualization at the nanoscale. Analytical techniques such as electron backscatter diffraction (EBSD), X-ray microanalysis (EDSX), and energy-filtered TEM (EFTEM) can also be extended to three dimensions, giving a world of new information relating structures to properties.

In situ nanoprocesses – The electron microscope becomes a lab in a chamber with ESEM and ETEM technologies allowing dynamic control over temperature, pressure, and gas type for in situ nanoprocess investigations. Researchers can visualize and correlate the structure, property, and function of materials undergoing chemical and physical processes such as catalysis, oxidation, reduction, polymerization, deformation and thermally induced phase transformations.

3D nanoprototyping – Nanoprototyping is a fast, simple way to design, fabricate, and test small-scale structures and devices using an electron beam or a focused ion beam. Site-specific milling, lithography, or chemical vapor deposition can all be carried out at the nanoscale to deliver high-quality 3D nanoprototyped structures.

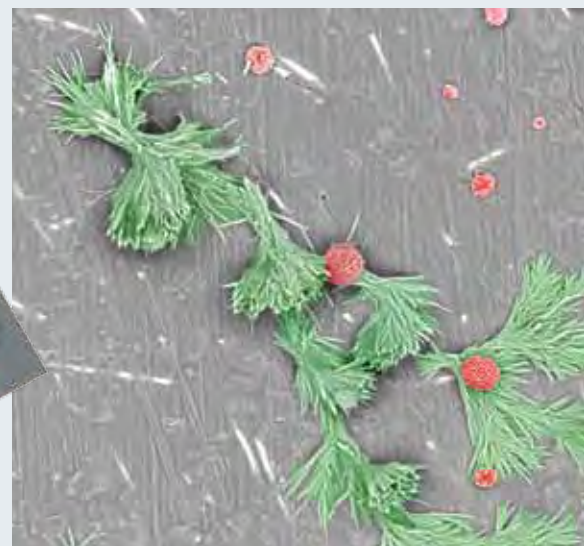
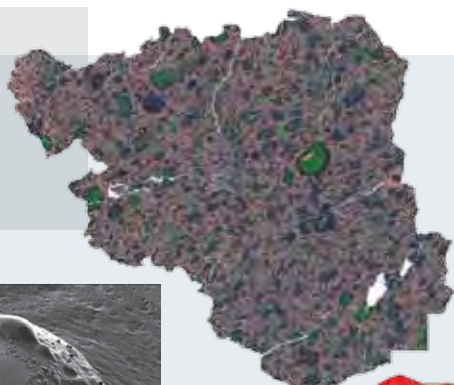

RESEARCH

gunshot residue

Glossary

Aberration

The deviation from perfect imaging in an optical system, caused by imperfections in the lens or by non-uniformity of the electron beam.

Accelerating voltage

The potential difference in an electron gun between cathode and anode over which electrons are accelerated. The higher the voltage, the faster the electrons (or ions) and the more penetrating power they have. Voltages may range from a few hundred volts up to several hundred thousand.

Airlock

A chamber within the electron microscope that can be isolated from the rest to allow the specimen to be inserted. The airlock is then pumped out and the specimen moved into the chamber (SEM, FIB) or column (TEM) vacuum. This reduces the amount of air and other contaminants brought into the column and speeds sample exchange.

Amplitude

The maximum value of a periodically varying parameter, as in the height of a wave crest above the mean value.

Amplitude contrast

Image contrast caused by the removal of electrons (or light) from the beam by interactions with the specimen.

Ångström

Unit of length, $1 \text{ \AA} = 0.1 \text{ nm}$.

Anode

In an electron gun, the negatively charged electrons are accelerated towards the anode, which has a positive charge relative to the filament (cathode) from which they emerge. In practice (for ease of construction), the filament has a high negative charge and the anode is at ground potential.

Aperture

A small hole in a metal disc used to stop those electrons that are not required for image formation (e.g., scattered electrons).

Astigmatism

A lens aberration in which the power of the lens is greatest in one direction and least in the perpendicular direction. It causes a round feature in the object to assume an elliptical shape in the image.

Atom

The smallest unit of physical matter that retains its elemental identity. There are many ways of looking at the atom. The most useful one for electron microscopists is to think of it as consisting of a positively charged nucleus (containing positively charged protons and uncharged neutrons) surrounded by negatively charged electrons in discrete orbits.

Atomic number

The number of protons in the atomic nucleus. This number determines the chemical nature of the atom. An atom of iron, for example, has 29 protons, an atom of oxygen 8, and so on.

Backscattered electrons

Primary (beam) electrons that have been deflected by the specimen through an angle generally greater than 90° so that they exit the sample with little or no loss of energy.

Binocular viewer

A light microscope built into a TEM for viewing a fine-grain fluorescent screen for critical focusing and astigmatism correction.

Cathodoluminescence

The emission of light photons by a material under electron bombardment.

Chromatic aberration

See aberration. The power of the lens varies with the wavelength of the electrons in the beam.

Column

The physical structure of an electron microscope that accommodates the evacuated electron beam path, the electromagnetic lenses, and the specimen (TEM) and aperture mechanisms.

Condenser lens

Part of the illumination system between the gun and the specimen designed to form the electron beam, usually into a parallel configuration as it transits the sample (TEM) or enters the objective lens (SEM). It may also be used to form a finely focused spot on the specimen (STEM).

Crystal

A material in which the atoms are ordered into rows and columns (a lattice) and because of this periodicity, electrons, whose wavelength is about the same size as the spacing between atoms, undergo diffraction.

Detector

A device for detecting particular electrons or photons in the electron microscope.

Diffraction

Deviation of the direction of light or other wave motion when the wave front passes the edge of an obstacle.

Diffraction contrast

Image contrast caused by the removal of electrons (or light) from the beam by scattering by a periodic (e.g., crystalline) structure in the specimen (diffraction).

EDX

Energy dispersive X-ray analysis or spectrometry (sometimes EDS). An EDX spectrometer makes a spectrum of X-rays emitted by the specimen on the basis of their energy.

EELS

Electron energy loss spectroscopy (or spectrometry) analyzes transmitted electrons on the basis of energy lost to interactions with sample atoms. Energy loss provides information about the sample atoms' elemental identity, chemical bonding, and electronic states.

Electron

Fundamental sub-atomic particle carrying a negative charge and conveniently described as orbiting the nucleus of the atom. Free electrons can easily flow in a conductor and can be extracted into a vacuum by an electric field.

Electron microscope

A microscope in which a beam of electrons is used to form a magnified image of the specimen.

Electrostatic lens

Device used to focus charged particles into a beam. Although they may also be used with electrons, they are most frequently used with ions in a FIB column. The much greater mass of ions requires the stronger optical power available from an electrostatic lens. Lighter electrons can be effectively focused by weaker magnetic lenses.

ESEM

Environmental scanning electron microscope – a scanning electron microscope that can accommodate a wide range of pressures in the sample chamber, up to that required to sustain water in its liquid phase.

ETEM

Environmental transmission electron microscope – a transmission electron microscope that can accommodate a wider range of environmental conditions and apparatus in the sample space to enable in situ examination of materials and processes.

Excitation

The input of energy to matter leading to the emission of radiation.

Excited atom

An atom which has a vacancy in one of its inner electron orbitals (see also ion) and therefore has a higher energy. It returns to its ground state when an electron from an outer orbital drops down to fill the vacancy, emitting the excess energy as an X-ray. The energy difference between orbitals and thus the energy of the X-ray is characteristic of the emitting atom's elemental identity.

FEG

Field emission gun, an electron source in which electrons are extracted from a sharply pointed tungsten tip by a very strong electric field.

FIB

Focused ion beam – similar to a SEM but using an ion beam instead of an electron beam. DualBeam instruments combine FIB and SEM.

Filament

Metal wire, usually in the form of a hairpin, which, when heated in vacuum, releases free electrons and so provides a source of electrons for an electron microscope.

Fluorescent screen

Large plate coated with a material (phosphor) which gives off light (fluoresces) when bombarded by electrons. A TEM may project its electron image onto a fluorescent screen to make it visible in real time.

Focal length of a lens

The distance (measured from the center of the lens in the direction of the beam) at which a parallel incident beam is brought to a focus.

Focusing

The act of making the image as sharp as possible by adjusting the power of the objective lens.

Goniometer

Specimen stage allowing linear movement of the specimen in two or more directions and rotation of the specimen in its own plane and tilting about one or more axes which remain fixed with respect to the beam.

Ground state

The lowest energy state of an atom.

Ion

An atom or molecule that has lost or gained an electron and therefore has a net positive or negative electric charge.

Ion getter pump

Vacuum pump which uses electric and magnetic fields to ionize and trap residual gas molecules by embedding them in the cathode of the pump.

Lattice

Regular three dimensional array of atoms in a crystal.

Lens

In a light microscope, a piece of transparent material with one or more curved surfaces, which is used to focus light. In an electron microscope, a similar effect is achieved on a beam of electrons by using a magnetic (or electrostatic) field.

LMIS

Liquid metal ion source – An ion source in which ions are extracted by a strong electric field from a layer of liquid metal Ga⁺ coating a sharply pointed electrode.

Micrometer

Unit of length (distance). One micrometer (μm) is a millionth of a meter (10^{-6} m) or 1000 nm.

Microtome

Instrument for cutting extremely thin sections from a specimen prior to examination in the microscope. In electron microscopy this is usually referred to as an ultramicrotome.

Nanometer

Unit of length (distance). One nanometer (nm) is a billionth of a meter (10^{-9} meter).

Objective lens

In a TEM, this is the first lens after the specimen whose function is to focus transmitted electrons into an image. In a SEM it is the last lens before the specimen and it produces the extremely fine electron spot with which the specimen is scanned. Its quality largely determines the performance of the microscope.

Oil diffusion pump

Vacuum pump where the pumping action is produced by the dragging action of a stream of oil vapor through an orifice.

Phase

Relative position in a cyclical or wave motion. It is expressed as an angle, one cycle or one wavelength corresponding to 360° .

Phase contrast

Image contrast caused by the interference among transmitted electrons with phase shifts caused by interaction with the sample.

Phase diagram

Graph of temperature and pressure showing the range of each under which a given material can exist in the solid, liquid, or vapor phase.

Photomultiplier

Electronic tube in which light is amplified to produce an electrical signal with very low noise.

Photons

Discrete packets of electromagnetic radiation. A light beam is made up of a stream of photons.

Primary electrons

Electrons in the beam.

Quantum

A discrete packet of energy, as a photon of light.

Raster

The track of the beam in a SEM or STEM. It is analogous to eye movements when reading a book: left to right, word by word, and down the page line by line.

Refraction

Changes in direction of a beam of light (or electrons) as the beam passes through regions in which its propagation speed changes.

Refractive index

The ratio of the speed of light in a vacuum to that in a given medium such as glass, water, or oil.

Resolving power

The ability to make points or lines which are closely adjacent in an object distinguishable in an image.

Resolution

A measure of resolving power.

Scanning

Process of investigating a specimen by moving a finely focused probe (electron beam) in a raster pattern over the surface.

Scintillation detector

Electron detector used in SEM or STEM in which electrons are accelerated towards a phosphor, which fluoresces to produce light, which is amplified by means of a photomultiplier to produce an electrical signal.

Secondary electrons

Electrons scattered from sample atoms by interactions with beam electrons.

SEM

Scanning electron microscope or scanning electron microscopy.

Semiconductor detector

Electron detector used in SEM or STEM in which a high energy electron is detected by the current it generates as it dissipates its energy in a solid state diode.

Spectrometer

Instrument for obtaining a spectrum.

Spectrum

A display produced by the separation of a complex radiation into its component intensity as a function of energy or wavelength.

Spherical aberration

See aberration. The power of a lens varies with radial distance from its center.

Sputter coater

Instrument for coating a non-conducting specimen with a very thin uniform layer of a conducting element such as gold or iridium to eliminate artifacts caused by accumulating charge.

STEM

Scanning transmission electron microscope or scanning transmission electron microscopy.

TEM

Transmission electron microscope or transmission electron microscopy.

Turbomolecular pump

Vacuum pump in which the molecules are moved against the pressure gradient by collisions with rapidly rotating, angled vanes.

Vacuum

A region of reduced (lower than ambient) gas pressure.

Wavelength

The distance on a periodic wave between two successive points at which the phase is the same, for example, two crests.

WDX

Wavelength dispersive X-ray analysis or spectrometry – an alternative to energy dispersive spectrometry for X-ray analysis. In WDX, X-rays are dispersed into a spectrum by diffraction from a crystal or grating. The crystal is mechanically scanned through a range of angles while a detector measures changes in signal intensity.

Wehnelt cylinder

An electrode between the cathode (filament) and the anode (ground) in a triode electron gun, used to form the beam and control its current.

Working distance

In a SEM the physical distance between the external metal parts of the objective lens and the specimen surface. This is the space available for placing certain electron, X-ray, and cathodoluminescence detectors. For highest resolution, the working distance has to be made as small as possible which leads to compromises.

X-rays

Electromagnetic radiation with wavelengths ranging from 10 to 0.01 nm, much shorter than visible light. In the electron microscope, characteristic X-rays are used to analyze elemental composition with high spatial resolution.

FEI would like to thank the following individuals for their contributions to this booklet

Dr. Daniel Beniac, Public Health Agency of Canada

Lyubov Belova, Royal Institute of Technology

Randy Burgess, Hewlett Packard

Dr. Clifford Barnes, University of Ulster

Laura Tormo Cifuentes, Museo Nacional de Ciencias Naturales-CSIC

Philippe Crassous, Ifremer

Angela DiFiore, RJ Lee Group, Inc

Christian Gspan, Institut für Elektronenmikroskopie

Paul Gunning, Smith & Nephew

Frans Holthuysen, Philips Research

Dr. Jim Ito, Yorkhill Hospital Glasgow Scotland, UK

Wann-Neng Jane, Academia Sinica

Craig Johnson

Avigail Keller

C. Kisielowski NCEM, UC Berkley

Alexey Kolomytsev, Taganrog University

Daniel Mathys, ZMB, Universität Basel

Oliver Meckes, Eye of Science

Nicole Ottawa, Eye of Science

Harald Plank, Institute for Electron Microscopy

Francisco Rangel, MCT/IINT/CETENE

Michael Rogers, Institut für Elektronenmikroskopie

Hagen Roetz, Infineon Technologies Dresden GmbH & Co. OHG

Dr. Harald Rösner, Institut für Materialphysik

J. Thibault, Marseille

Dr. Matthew Weyland, Monash Centre for Electron Microscopy

Hong Zhou, University of California at Los Angeles, USA

FEI NanoPort and Applications Engineers

FEI.com provides a wealth of information on the latest technologies and innovations from the world of electron microscopy and nanotechnology. To learn more about FEI Company, our products, and solutions, visit us on the Web at www.fei.com.

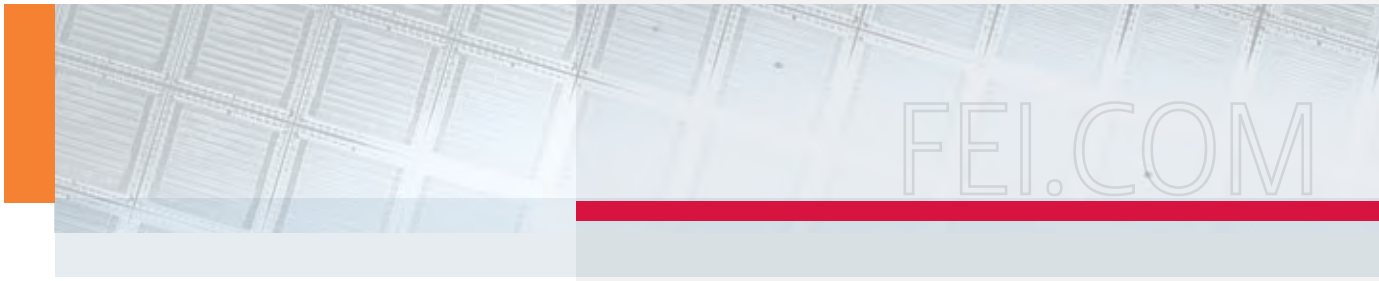

Every effort has been made to ensure the accuracy of the content therein. Report errors or oversights using our online feedback form located at <http://www.fei.com/feedback.aspx>

As part of our commitment to responsible use of resources, we've produced this communication on a recycled stock that contains 30% post-consumer waste.

TÜV Certification for design, manufacture, installation and support of focused ion- and electron-beam microscopes.

© 2010. We are constantly improving the performance of our products, so all specifications are subject to change without notice. FEI is a registered trademark, and DualBeam, Nova, Magellan, Titan, Tecnai Osiris, V400ACE, Vitrobot, and the FEI logo are trademarks of FEI Company. All other trademarks belong to their respective owners.

OT0005 07-2010

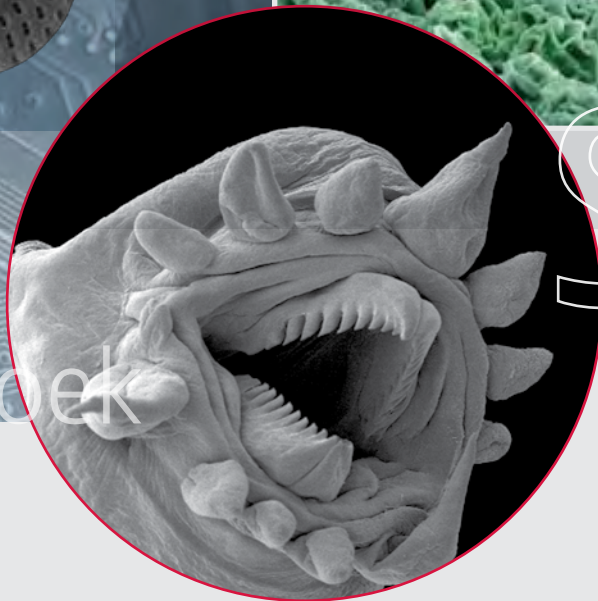
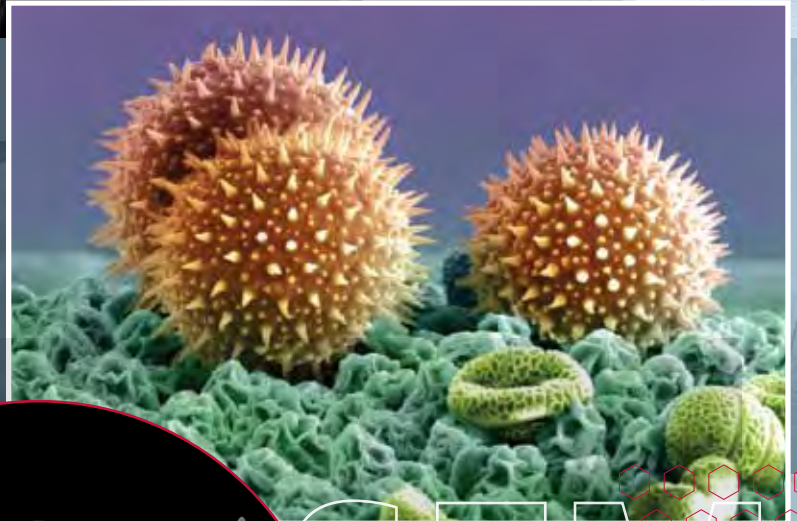
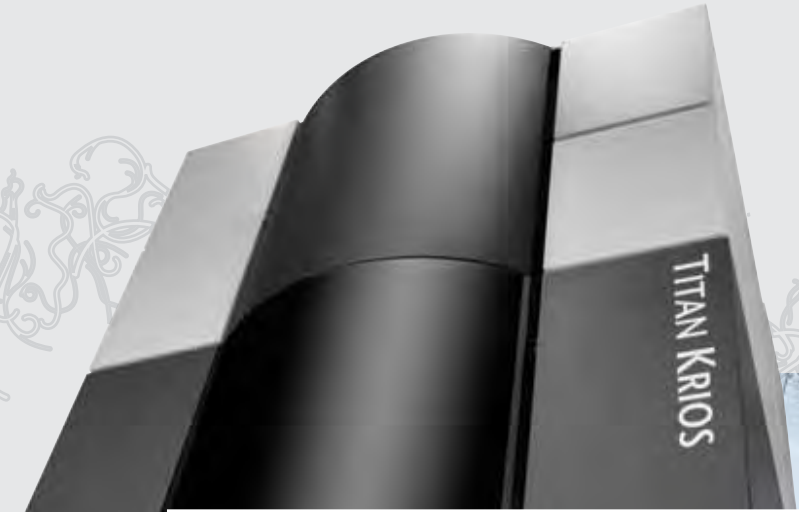
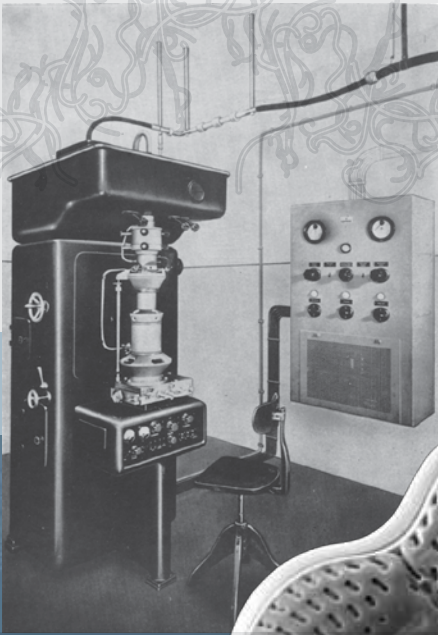

SEM

Leeuwenhoek

ISBN 978-0-578-06276-1

90000>



9 780578 062761

AN INTRODUCTION TO **electron microscopy**

